

Agilent 1142A Probe Control and Power Module

User's Guide



Agilent Technologies

Notices

© Agilent Technologies, Inc. 2000 – 2014

No part of this manual may be reproduced in any form or by any means (including electronic storage and retrieval or translation into a foreign language) without prior agreement and written consent from Agilent Technologies, Inc. as governed by United States and international copyright laws.

Manual Part Number

01142-97003

Edition

August 2014

Printed in Malaysia

Agilent Technologies, Inc.
1601 California Street
Palo Alto, CA 94304, USA

Warranty

The material contained in this document is provided "as is," and is subject to being changed, without notice, in future editions. Further, to the maximum extent permitted by applicable law, Agilent disclaims all warranties, either express or implied, with regard to this manual and any information contained herein, including but not limited to the implied warranties of merchantability and fitness for a particular purpose. Agilent shall not be liable for errors or for incidental or consequential damages in connection with the furnishing, use, or performance of this document or of any information contained herein. Should Agilent and the user have a separate written agreement with warranty terms covering the material in this document that conflict with these terms, the warranty terms in the separate agreement shall control.

Technology Licenses

The hardware and/or software described in this document are furnished under a license and may be used or copied only in accordance with the terms of such license.

Restricted Rights Legend

If software is for use in the performance of a U.S. Government prime contract or subcontract, Software is delivered and licensed as "Commercial computer software" as defined in DFAR 252.227-7014 (June 1995), or as a "commercial item" as defined in FAR 2.101(a) or as "Restricted computer software" as defined in FAR 52.227-19 (June 1987) or any equivalent agency regulation or contract clause. Use, duplication or disclosure of Software is subject to Agilent Technologies' standard commercial license terms, and non-DOD Departments and Agencies of the U.S. Government will receive no greater than Restricted Rights as defined in FAR 52.227-19(c)(1-2) (June 1987). U.S. Government users will receive no greater than Limited Rights as defined in FAR 52.227-14 (June 1987) or DFAR 252.227-7015 (b)(2) (November 1995), as applicable in any technical data.

Safety Notices

CAUTION. A **CAUTION** notice denotes a hazard. It calls attention to an operating procedure, practice, or the like that, if not correctly performed or adhered to, could result in damage to the product or loss of important data. Do not proceed beyond a **CAUTION** notice until the indicated conditions are fully understood and met.

WARNING. A **WARNING** notice denotes a hazard. It calls attention to an operating procedure, practice, or the like that, if not correctly performed or adhered to, could result in personal injury or death. Do not proceed beyond a **WARNING** notice until the indicated conditions are fully understood and met.

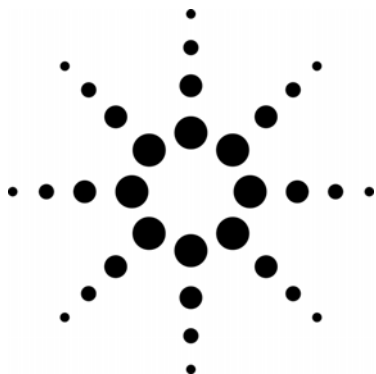

1142A Probe Control and Power Module

Using the 1142A 5
 Safety Information 8
 Performance Test 11
 Specifications and Characteristics 13
 Service 15
 Replaceable Parts 19
 Contacting Agilent 32

The 1142A supplies two sets of positive and negative voltages for use by active probes. For the 1141A probe it also supplies an offset current. Refer to the *1141A Differential Probe and 1142A Probe Control and Power Module User and Service Guide* for more information.

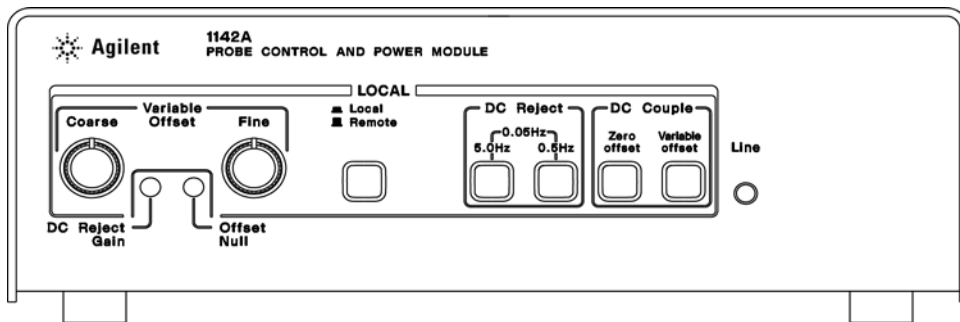

Figure 1 1142A Probe Control and Power Module

Before connecting your Agilent probe to the 1142A, refer to the probe's user's guide to learn how to perform measurements. This manual contains information for use and service of the 1142A by itself. It covers use of the 1142A as a power supply only and service of the instrument in general. Use of the offset controls is covered in the probe or oscilloscope manual.

Parts Supplied

The following items are supplied with the 1142A.

- One power cord
- One operating and service guide

Accessories Available

A fan-out adapter is available to power two probes with one supply.

- Fan-out adapter, part number 01144-61604

Instruments Covered by Manual

The 1142A's rear-panel serial number sticker is in the form: 0000A00000. The first four digits and letter are the serial prefix, while the last five digits are the suffix. The prefix is the same for all identical instruments, and it changes only when a change has been made to the instrument. The suffix however, is assigned sequentially and is different for each instrument. The contents of this manual apply to instruments with the serial number prefixes 3050A.

Using the 1142A

This section of the manual contains information and instructions for installation and use of the 1142A Probe Control and Power Module as an auxiliary power supply. Use of probe controls is covered in the guide for the probe.

Initial Inspection

- 1** Inspect the shipping container for damage. Keep a damaged shipping container or cushioning material until the contents of the shipment have been checked for completeness and the instrument has been checked mechanically and electrically.
- 2** Check the accessories. If the contents are incomplete or damaged notify your Agilent Technologies Sales Office.
- 3** Inspect the instrument.
 - a** If there is mechanical damage or defect, or if the instrument does not operate properly or pass performance tests, notify your Agilent Technologies Sales Office.
 - b** If the shipping container is damaged, or the cushioning materials show signs of stress, notify the carrier as well as your Agilent Technologies Sales Office. Keep the shipping materials for the carrier's inspection. The Agilent Technologies Office will arrange for repair or replacement at Agilent Technologies' option without waiting for claim settlement.

Checking the Power Requirements and Fuse

The power module requires a power source of either 115 Vac or 230 Vac, 47 to 440 Hz, 25VA maximum.

CAUTION

BEFORE CONNECTING POWER TO THIS INSTRUMENT, be sure the line voltage select switch on the instrument's rear panel is set properly. Applying a voltage excessive to the setting may open the protective fuse.



The rear-panel fuse (F1) is a 0.25A, 250V time-delay fuse. The fuse used is the same regardless of line voltage selection. To replace the fuse:

- 1 Locate the fuse holder shown in [Figure 2](#). Gently push the fuse holder in using your finger or a flat-bladed screwdriver.
- 2 While the fuse holder is pushed in, gently turn the fuse holder counterclockwise.

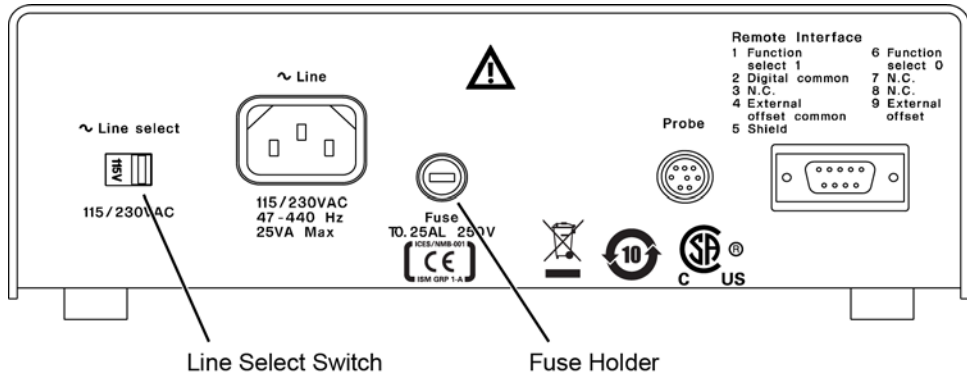

Figure 2 1142A Rear Panel

WARNING

SHOCK HAZARD! BEFORE YOU CONNECT THIS INSTRUMENT TO MAINS POWER OR LIVE MEASURING CIRCUITS you must provide a protective earth ground. The Mains plug must be inserted in a socket outlet provided with a protective earth contact. Do not use an extension cord (power cable) without a protective conductor (grounding). Grounding one conductor of a two-conductor outlet does not provide an instrument ground. Failure to provide a protective earth ground could result in a shock hazard if there is a failure in this instrument or equipment connected to it.

The 1142A is provided with a three-wire power cable. When connected to an appropriate ac power outlet, this cable grounds the instrument cabinet. The type of power cable plug shipped with the instrument depends on the country of destination.

The 1142A has no power switch. It is not required because of the low mains power requirement.

To Clean the Instrument









If the 1142A requires cleaning, perform the following steps:

- 1** Remove power from the instrument.
- 2** Clean the external surfaces of the instrument with a soft, dry cloth. Make sure that the instrument is completely dry before reconnecting it to a power source.

Safety Information

The following general safety precautions must be observed during all phases of operation of this instrument. Failure to comply with these precautions or with specific warnings or operating instructions in the product manuals violates safety standards of design, manufacture, and intended use of the instrument. Agilent Technologies assumes no liability for the customer's failure to comply with these requirements.

Table 1 Instrument Markings

Marking	Description
	Instruction manual symbol: the product is marked with this symbol when it is necessary for you to refer to the instruction manual in order to protect against damage to the product. "Caution" or "Warning" risk of danger marked on product. Refer to "Safety Information" on page 8.
	Hazardous voltage symbol.
	Earth terminal symbol. Used to indicate a circuit common connected to grounded chassis.
	Indicates AC (Alternating Current).
	The CE mark of the European Community.
	The CSA mark.
	This symbol indicates the Environmental Protection Use Period (EPUP) for the product's toxic substances for the China RoHS requirements.
	This product complies with the WEEE Directive marking requirements.

General

Do not use this product in any manner not specified by the manufacturer. The protective features of this product may be impaired if it is used in a manner not specified in the operation instructions.

WARNING

Only fuses with the required rated current, voltage, and specified type (normal blow, time delay, etc.) should be used. Do not use repaired fuses or short-circuited fuseholders. To do so could cause a shock or fire hazard.

This apparatus has been designed and tested in accordance with IEC Publication 348, Safety Requirements for Measuring Apparatus, and has been supplied in a safe condition. This is a Safety Class I instrument (provided with terminal for protective earthing). Before applying power, verify that the correct safety precautions are taken as described in the following warnings. In addition, note the external markings on the instrument as described in [Table 1](#) on page 8.

WARNING

If the instrument is damaged, or if it fails to operate according to the characteristics in this manual, remove the power cord and contact Agilent Technologies.

WARNING

Before turning on the instrument, you must connect the protective earth terminal of the instrument to the protective conductor of the (mains) power cord. The mains plug shall only be inserted in a socket outlet provided with a protective earth contact. You must not negate the protective action by using an extension cord (power cable) without a protective conductor (grounding). Grounding one conductor of a two-conductor outlet is not sufficient protection.

WARNING

If you energize this instrument by an auto transformer (for voltage reduction or mains isolation), the common terminal must be connected to the earth terminal of the power source.

WARNING

Whenever it is likely that the ground protection is impaired, you must make the instrument inoperative and secure it against any unintended operation.

1142A Probe Control and Power Module
Safety Information

WARNING

Service instructions are for trained service personnel. To avoid dangerous electric shock, do not perform any service unless qualified to do so. Do not attempt internal service or adjustment unless another person, capable of rendering first aid and resuscitation, is present.

WARNING

Do not install substitute parts or perform any unauthorized modification to the instrument.

WARNING

Capacitors inside the instrument may retain a charge even if the instrument is disconnected from its source of supply.

WARNING

Do not operate the instrument in the presence of flammable gases or fumes. Operation of any electrical instrument in such an environment constitutes a definite safety hazard.

WARNING

When unplugging the power cord from the power receptacle or from the unit, grasp the plug, not the cord, in order to avoid damaging the cable.

Performance Test

This section documents the Output Voltages Performance Test which tests the electrical performance of the 1142A. There are no service adjustments.

The performance test procedures may be performed for incoming inspection of the instrument and should be performed periodically thereafter to ensure and maintain peak performance. Amount of use, environmental conditions, and the user's experience concerning need for testing will contribute to verification requirements.

NOTE

If this supply is used with an 1141A Differential Probe, use the procedures in the user and service guide supplied with the probe.

Equipment Required

A DVM with 0.5% accuracy or a 34401A digital multimeter is required.

Adjustments

There are no service adjustments on the 1142A.

Output Voltages Performance Test

The output voltages are tested at the rear-panel connector.

- 1 Connect the instrument to the mains power.
- 2 Measure the power supply voltages ($\pm 6V$ and $\pm 15V$, $\pm 3.0\%$) on the rear-panel power connector as listed in [Table 2](#) on page 12.

1142A Probe Control and Power Module
Performance Test

Table 2 Voltage Outputs on Rear-Panel Connector

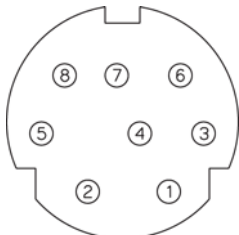
Connector	Pin	Voltage
	1	LF Signal
	2	Offset Out
	3	+6V
	4	-15V
	5	Offset Common
	6	+15V
	7	Power Common
	8	-6V

Specifications and Characteristics

There are no specifications for the 1142A Probe Control and Power module as a stand-alone instrument. As it is designed to be used specifically with certain active probes, its characteristics are coupled with the performance of the probe. When used only as a power supply, the 1142A provides $\pm 6V$ and $\pm 15V$ at $\pm 3\%$.

General Characteristics The following characteristics apply to the 1141A Differential Probe with the 1142A Probe Control and Power Module.

Table 3 Environmental Conditions

Item	Characteristic
Use	Indoor
Temperature	
Operating	0° C to +55° C (32° F to +131° F)
Non-operating	-40° C to +70° C (-40° F to +158° F)
Humidity	
Operating	Up to 95% relative humidity (non-condensing) at +40° C (+104° F)
Non-operating	Up to 90% relative humidity at +65° C (+149° F)
Altitude	
Operating	Up to 4,600 meters (15,000 ft)
Non-operating	Up to 15,300 meters (50,000 ft)
Vibration	
Operating	Random vibration 5 to 500 Hz, 10 minutes per axis, 0.3, Grms.
Non-operating	Random vibration 5 to 500 Hz, 10 minutes per axis, 2.41 Grms. Resonant search 5 to 500 Hz swept sine, 1 Octave/minute sweep rate, (0.75G), 5 minute resonant dwell at 4 resonances per axis.

1142A Probe Control and Power Module Specifications and Characteristics

Table 4 Power Requirements

Item	Specification
Voltage	115/230 Vac, 47 to 440 Hz
Power	25 VA maximum

Table 5 Weight

Item	Specification
Net	1.8 kg (4.0 lb)
Shipping	approximately 2.7 kg (6.0 lb)

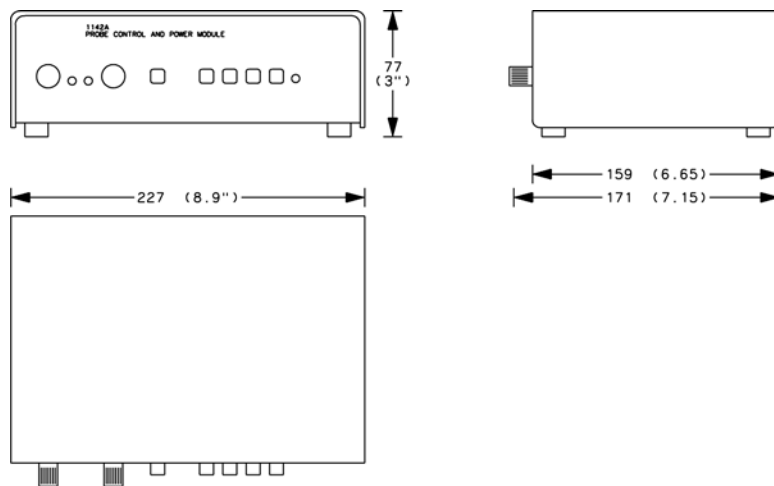

Figure 3 Dimensions

Recommended Test Equipment

The only piece of test equipment needed for testing and troubleshooting this instrument is a digital multimeter with at least 0.5% voltage measurement accuracy. A 34401A is sufficient.

Service

This section provides troubleshooting, service, and repair information for the 1142A Probe Control and Power Module. The troubleshooting information is provided to isolate a faulty assembly. When a faulty assembly has been located, the disassembly/assembly procedures help direct replacement of the assembly.

The service policy for the 1142A Probe Control and Power Module is component-level repair.

Safety

Read the “[Safety Information](#)” on page 8 before servicing the instrument. Before performing any procedure, review it for cautions and warnings.

WARNING

Maintenance should be performed by trained service personnel aware of the hazards involved (for example, fire and electric shock). When maintenance can be performed without power applied, the power cord must be removed from the instrument.

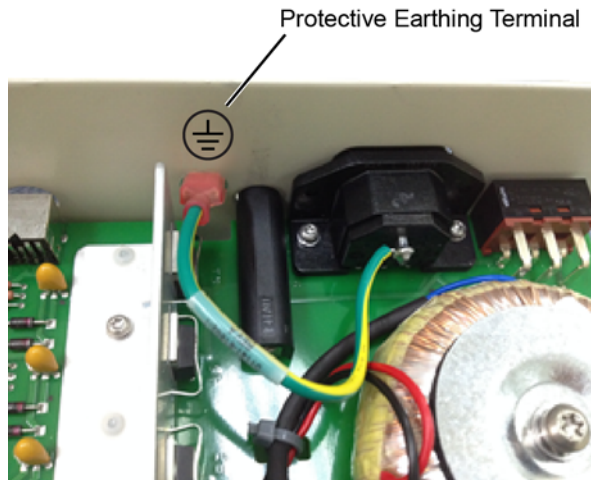

Figure 4 Location of Protective Earthing Terminal

Troubleshooting

The circuitry consists of simple power supplies, operational amplifiers, and TTL logic. Use conventional troubleshooting techniques. A complete parts list, component location, and schematics are provided later in this chapter.

Theory of Operation

The following discussion covers block-level theory for the 1142A Probe Control and Power Module.

The control and power module provides offset functions, local and remote control, and power to an 1141A Differential Probe. For more complete information about how this power module is used with the differential probe, see the service section of the user and service guide for the probe.

Offset Functions

There are two offset functions developed in the control module: variable offset and dc reject. A variable offset voltage with coarse and fine adjustments can be selected by the front panel controls. The offset level is buffered by U8 and selected by multiplexer U3 as the input to offset amp U7. The output of the offset amp is summed with the low frequency signal and feedback which gives dc coupling in the probe.

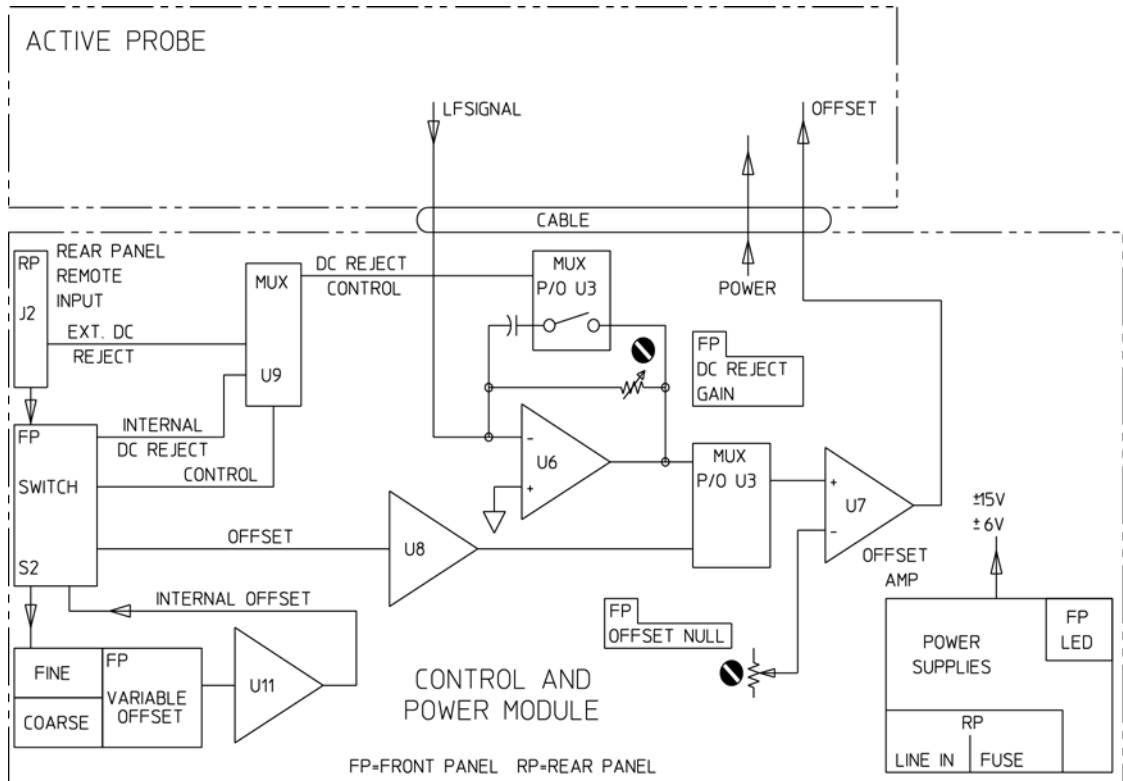

Figure 5 A1 Control and Power Module Block Diagram

Front panel screwdriver adjustment Offset Null zeros the dc output from the probe when the dc input and offset are zero.

For dc Reject, an output from the low-frequency amplifier in the probe (LFSIG) is used to develop a voltage used to null the dc component of the input signal. LFSIG is an input to U6, an inverting amplifier and low-pass filter. Multiplexer U3 selects one of three capacitors to set a roll-off frequency of 0.05, 0.5, or 5 Hz. The output of U6 is selected, again by U3, as the input to the offset amp. When the output of the offset amp is summed into the low frequency path, the result is cancellation of the dc component of the input signal. Front panel screwdriver adjustment DC Reject Gain adjusts the gain of the dc reject circuit.

Local and Remote Control

The front panel switch controls the dc reject and offset functions. It also selects remote operation, which allows control through the rear panel remote input connector.

Power Supply

The power supply provides $\pm 6V$ and $\pm 15V$ for the probe and analog control circuitry as well as $+5V$ for the digital control circuitry.

Removing and Replacing Assemblies

Use the following procedure to disassemble the probe control and power module.

WARNING

Hazardous voltages exist on the power supply. To avoid electrical shock, adhere closely to the following procedures.

- 1 Remove the power cord.
- 2 Remove four flathead screws and remove the top cover.

WARNING

Be sure to reconnect the safety ground when reassembling the instrument.

- 3 Unplug the safety ground from the tab on the rear panel of the instrument.
- 4 Note the orientation of the knobs. Remove the two knobs.
- 5 On the bottom of the instrument, remove the 5 mm screw that fastens the transformer support.
- 6 Remove the following pan-head screws.
 - Three directly on the PC board.
 - Two on the ac input connector.
 - Two on the heat sink.
- 7 Remove the PC board. Slide it slightly forward so parts will clear the rear panel, then lift the rear of the board out while sliding it backwards.
- 8 Remove the two heat sink spacers from the standoffs that were directly under the heat sink.
- 9 Reverse the procedure to reassemble the control and power supply.

Replaceable Parts

This section contains information for ordering parts. Service support for the 1142A is to the component level.

Ordering Information

To order a part in the material list, quote the part number, indicate the quantity desired, and address the order to the nearest Agilent Technologies Sales Office.

To order a part not listed in the material list, include the instrument part number, instrument serial number, a description of the part (including its function), and the number of parts required. Address the order to the nearest Agilent Technologies Service Center.

Direct Mail Order System

Within the USA, Agilent Technologies can supply parts through a direct mail order system. There are several advantages to this system:

- Direct ordering and shipment from the Agilent Technologies parts center in California, USA.
- No maximum or minimum on any mail order (there is a minimum amount for parts ordered through a local Agilent Technologies Sales Office when the orders require billing and invoicing).
- Prepaid transportation (there is a small handling charge for each order).
- No invoices.

In order for Agilent Technologies to provide these advantages, a check or money order must accompany each order.

Mail order forms and specific ordering information are available through your local Agilent Technologies office. Addresses and telephone numbers are located in a separate document shipped with the manuals.

Manufacturers' Codes

A list of manufacturers' codes is given in [Table 6](#) on page 20. The codes are given for parts in the parts lists. The table gives the manufacturer and address for each code.

Table 6 Manufacturers' Code List

Mfr. No.	Name	Address
00000	Any satisfactory supplier	
04713	Motorola Semiconductor Products,	Phoenix,, AZ 85008
06665	Precision Monolithics Inc,	Santa Clara,, CA 95050
24546	Corning Glass Works (Bradford)	Bradford,, PA 16701
27014	National Semiconductor Corp	Palo Alto,, CA 94304
,28480	Agilent Technologies	Santa Rosa, CA 95403
32997	Bourns Inc	Riverside,, CA 92507

Parts Lists

The replaceable parts lists include all parts relevant to the applicable service levels. [Table 7](#) on page 21 lists the replaceable parts to the assembly level. [Table 8](#) on page 22 lists parts for the A1 PC assembly. The information given for each part consists of the following:

- Reference designator.
- part number.
- Part number Check Digit (CD).
- Total quantity (Qty) in instrument or on assembly. The total quantity is given once and at the first appearance of the part number in the list.
- Description of the part.
- Typical manufacturer of part in an identifying five-digit code.

**1142A Probe Control and Power Module
Replaceable Parts**

Table 7 1142A Replaceable Parts

Ref.Des.	Part Number	Qty	Description	Mfr.Code	Mfr. Part Number
A1	01142-66501	1	PC ASSEMBLY-POWER AND CONTROL	28480	01142-66501
H1	0515-0374	7	SCREW-MACHINE M3 10MM-LG	00000	ORDER BY DESCRIPT.
H2	0515-1031	4	SCREW-MACH M3 6MM-LG 90-DEG-FLH-HD	00000	ORDER BY DESCRIPT.
H3	0515-1579	1	SCREW-MACHINE M5 18MM-LG	00000	ORDER BY DESCRIPT.
MP1	01142-47701	1	BOTTOM CHASSIS	28480	01142-47701
MP2	01142-44101	1	TOP CHASSIS	28480	01142-44101
MP3	01142-24701	2	SPACER-HEAT SINK	28480	01142-24701
MP4	0370-1097	2	KNOB-POINTER	28480	0370-1097
MP5	0403-0727	4	FOOT	28480	0403-0727
MP6	5041-0234	5	KEYCAP	28480	5041-0234
W1	8120-1521	1	POWER CORD 18-AWG 3-COND 90-IN-LG	28480	8120-1521

**1142A Probe Control and Power Module
Replaceable Parts**

Table 8 A1 Power Supply PC Replaceable Parts (Sheet 1 of 4)

Ref.Des.	Part Number	Qty	Description	Mfr. Code	Mfr. Part Number
C1	0160-6190	2	CAPACITOR-FXD 0.33UF +-10% 50VDC	28480	0160-6190
C2	0160-5474	1	CAPACITOR-FXD 0.1UF +-5% 100VDC MET-POLY	28480	0160-5474
C3	0180-3298	2	CAPACITOR-FXD 2200UF+30-10% 50VDC AL	28480	0180-3298
C4	0180-3298		CAPACITOR-FXD 2200UF+30-10% 50VDC AL	28480	0180-3298
C5	0160-6500	4	CAPACITOR-FXD 0.01UF +-10% 100VDC CER	28480	0160-6500
C6	0160-6500		CAPACITOR-FXD 0.01UF +-10% 100VDC CER	28480	0160-6500
C7	0160-6500		CAPACITOR-FXD 0.01UF +-10% 100VDC CER	28480	0160-6500
C8	0160-6500		CAPACITOR-FXD 0.01UF +-10% 100VDC CER	28480	0160-6500
C9	0180-3845	4	CAPACITOR-FXD 4.7UF+-10% 35VDC TA	28480	0180-3845
C10	0180-3845		CAPACITOR-FXD 4.7UF+-10% 35VDC TA	28480	0180-3845
C11			NOT ASSIGNED		
C12	0160-5581	1	CAPACITOR-FXD 0.033UF +-10% 63VDC	28480	0160-5581
C13	0160-6190		CAPACITOR-FXD 0.33UF +-10% 50VDC	28480	0160-6190
C14	0160-7060	1	CAPACITOR-FXD 3.3UF+-10% 63V	28480	0160-7060
C15	0160-4801	1	CAPACITOR-FXD 100PF +-5% 100VDC CER	28480	0160-4801
C16	0180-3845		CAPACITOR-FXD 4.7UF+-10% 35VDC TA	28480	0180-3845
C17	0180-3845		CAPACITOR-FXD 4.7UF+-10% 35VDC TA	28480	0180-3845
C18			NOT ASSIGNED		
C19	0160-5471	1	CAPACITOR-FXD 0.1UF +-5% 50VDC MET-POLY	28480	0160-5471
C20	0160-5469	1	CAPACITOR-FXD 1UF +-10% 50VDC MET-POLY	28480	0160-5469
C21-22			NOT ASSIGNED		
C23	0180-3784	4	CAPACITOR-FXD 22UF+-20% 25VDC TA	28480	0180-3784
C24	0180-3784		CAPACITOR-FXD 22UF+-20% 25VDC TA	28480	0180-3784
C25	0180-3784		CAPACITOR-FXD 22UF+-20% 25VDC TA	28480	0180-3784
C26	0180-3784		CAPACITOR-FXD 22UF+-20% 25VDC TA	28480	0180-3784
CR1			NOT ASSIGNED		
CR2	1901-1081	2	DIODE-PWR RECT 100V 3A	04713	MR501
CR3	1901-1081		DIODE-PWR RECT 100V 3A	04713	MR501

Table 8 A1 Power Supply PC Replaceable Parts (Sheet 2 of 4)

Ref.Des.	Part Number	Qty	Description	Mfr. Code	Mfr. Part Number
CR4			NOT ASSIGNED		
CR5	1901-0731	8	DIODE-PWR RECT 400V 1A	28480	1901-0731
CR6	1901-0731		DIODE-PWR RECT 400V 1A	28480	1901-0731
CR7-8			NOT ASSIGNED		
CR9	1901-0731		DIODE-PWR RECT 400V 1A	28480	1901-0731
CR10	1901-0731		DIODE-PWR RECT 400V 1A	28480	1901-0731
CR11	1901-0731		DIODE-PWR RECT 400V 1A	28480	1901-0731
CR12	1901-0731		DIODE-PWR RECT 400V 1A	28480	1901-0731
CR13	1901-0734	2	DIODE-PWR RECT 1N5818 30V 1A	04713	1N5818
CR14	1901-0734		DIODE-PWR RECT 1N5818 30V 1A	04713	1N5818
CR15-16			NOT ASSIGNED		
CR17	1901-0731		DIODE-PWR RECT 400V 1A	28480	1901-0731
CR18	1901-0731		DIODE-PWR RECT 400V 1A	28480	1901-0731
DS1	1990-0521	1	LED-LAMP LUM-INT=2.2MCD IF=50MA-MAX	28480	5082-4955
E1	2110-0642	1	FUSEHOLDER 6.3A 250 V	28480	2110-0642
E2	2110-0565	1	FUSEHOLDER CAP	28480	2110-0565
F1	2110-0201	1	FUSE 0.25A 250V TD	28480	2110-0201
H1	0515-1579	1	SCREW-MACHINE M5 18MM-LG	28480	0515-1579
HS1	01142-21101	1	HEAT SINK	28480	01142-21101
J1	1251-4743	1	CONNECTOR-AC PWR	28480	1251-4743
J2	1252-1487	1	CONN-RECT D-SUBMIN 9-CKT (remote)	28480	1252-1487
J3	1252-3134	1	CONNECTOR-ROUND 8-CKT (probe)	28480	1252-3134
MP1	1400-1604	1	LED MOUNT	28480	1400-1604
MP2	1205-0732	4	SPRING CLIP	28480	1205-0732
MP3	0361-0685	3	RIVET-BLIND DR-PIN RNDH 0.125DIA	28480	0361-0685
MP4	0340-1211	4	INSULATOR-THERMAL	28480	0340-1211
MP5-6			NOT ASSIGNED		
MP7	1400-0249	1	CABLE TIE 0.062-0.625-DIA 0.091-WD NYL	16956	08-465/GRAY
MP8	01142-24702	1	TRANSFORMER SUPPORT	28480	01142-24702
MP9	01142-28801	1	WASHER-TRANSFORMER SUPPORT	28480	01142-28801

1142A Probe Control and Power Module
Replaceable Parts

Table 8 A1 Power Supply PC Replaceable Parts (Sheet 3 of 4)

Ref.Des.	Part Number	Qty	Description	Mfr. Code	Mfr. Part Number
R1-2			NOT ASSIGNED		
R3	0757-0442	4	RESISTOR 10K 1% 0.125W TF TC=0+-100	24546	CT4-1/8-T0-1002-F
R4	0757-0465	1	RESISTOR 100K 1% 0.125W TF TC=0+-100	24546	CT4-1/8-T0-1003-F
R5	0757-0199	5	RESISTOR 21.5K 1% 0.125W TF TC=0+-100	24546	CT4-1/8-T0-2152-F
R6	0757-0199		RESISTOR 21.5K 1% 0.125W TF TC=0+-100	24546	CT4-1/8-T0-2152-F
R7	0698-4431	2	RESISTOR 2.05K 1% 0.125W TF TC=0+-100	24546	CT4-1/8-T0-2051-F
R8	0699-1203	4	RESISTOR 120 0.1% 0.125W TF TC=0+-25	28480	0699-1203
R9	0757-0434	2	RESISTOR 3.65K 1% 0.125W TF TC=0+-100	24546	CT4-1/8-T0-3651-F
R10	0698-4431		RESISTOR 2.05K 1% 0.125W TF TC=0+-100	24546	CT4-1/8-T0-2051-F
R11	0699-1203		RESISTOR 120 0.1% 0.125W TF TC=0+-25	28480	0699-1203
R12	0757-0434		RESISTOR 3.65K 1% 0.125W TF TC=0+-100	24546	CT4-1/8-T0-3651-F
R13	0757-0420	1	RESISTOR 750 1% 0.125W TF TC=0+-100	24546	CT4-1/8-T0-751-F
R14	0698-4002	2	RESISTOR 5K 1% 0.125W TF TC=0+-100	24546	CT4-1/8-T0-5001-F
R15	0699-1203		RESISTOR 120 0.1% 0.125W TF TC=0+-25	28480	0699-1203
R16	0698-6317	2	RESISTOR 500 0.1% 0.125W TF TC=0+-25	28480	0698-6317
R17	0698-4002		RESISTOR 5K 1% 0.125W TF TC=0+-100	24546	CT4-1/8-T0-5001-F
R18	0699-1203		RESISTOR 120 0.1% 0.125W TF TC=0+-25	28480	0699-1203
R19	0698-6317		RESISTOR 500 0.1% 0.125W TF TC=0+-25	28480	0698-6317
R20			NOT ASSIGNED		
R21	0698-8827	1	RESISTOR 1M 1% 0.125W TF TC=0+-100	28480	0698-8827
R22	0757-0442		RESISTOR 10K 1% 0.125W TF TC=0+-100	24546	CT4-1/8-T0-1002-F
R23	0757-0427	1	RESISTOR 1.5K 1% 0.125W TF TC=0+-100	24546	CT4-1/8-T0-1501-F
R24	0757-0401	1	RESISTOR 100 1% 0.125W TF TC=0+-100	24546	CT4-1/8-T0-101-F
R25	2100-3161	1	RESISTOR-TRMR 20K 10% TKF SIDE-ADJ	32997	3006P-1-203
R26	2100-3056	1	RESISTOR-TRMR 5K 10% TKF SIDE-ADJ 17-TRN	32997	3006P-1-502
R27	0757-0199		RESISTOR 21.5K 1% 0.125W TF TC=0+-100	24546	CT4-1/8-T0-2152-F
R28	0757-0199		RESISTOR 21.5K 1% 0.125W TF TC=0+-100	24546	CT4-1/8-T0-2152-F
R29	0757-0442		RESISTOR 10K 1% 0.125W TF TC=0+-100	24546	CT4-1/8-T0-1002-F
R30	0757-0442		RESISTOR 10K 1% 0.125W TF TC=0+-100	24546	CT4-1/8-T0-1002-F
R31	0757-0280	1	RESISTOR 1K 1% 0.125W TF TC=0+-100	24546	CT4-1/8-T0-1001-F

Table 8 A1 Power Supply PC Replaceable Parts (Sheet 4 of 4)

Ref.Des.	Part Number	Qty	Description	Mfr. Code	Mfr. Part Number
R32	0757-0460	1	RESISTOR 61.9K 1% 0.125W TF TC=0+-100	24546	CT4-1/8-T0-6192-F
R33-39			NOT ASSIGNED		
R40	0757-0123	1	RESISTOR 34.8K 1% 0.125W TF TC=0+-100	28480	0757-0123
R41	2100-4250	2	RESISTOR-VAR 10K 20%	28480	2100-4250
R42	2100-4250		RESISTOR-VAR 10K 20%	28480	2100-4250
R43	0757-0458	1	RESISTOR 51.1K 1% 0.125W TF TC=0+-100	24546	CT4-1/8-T0-5112-F
R44	0683-2755	1	RESISTOR 2.7M 5% 0.25W CF TC=0-900	28480	0683-2755
R45	0698-4517	1	RESISTOR 127K 1% 0.125W TF TC=0+-100	24546	CT4-1/8-T0-1273-F
R46	0698-3271	1	RESISTOR 115K 1% 0.125W TF TC=0+-100	24546	CT4-1/8-T0-1153-F
R47	0698-8961	1	RESISTOR 909K 1% 0.125W TF TC=0+-100	28480	0698-8961
R48	0757-0199		RESISTOR 21.5K 1% 0.125W TF TC=0+-100	24546	CT4-1/8-T0-2152-F
RP1	1810-1242	1	RESISTOR-NETWORK	28480	1810-1242
S1	3101-2609	1	SWITCH-SL DPDT STD 5A 250VAC PC	28480	3101-2609
S2	3101-3007	1	SWITCH-6 STATION ASSEMBLY	28480	3101-3007
T1	9100-4750	1	TRANSFORMER-POWER (with mtg. hdwr.)	28480	9100-4750
U1	1826-1403	2	IC V RGLTR-ADJ-POS 3/40V	00000	LT317AT
U2	1826-1670	2	IC V RGLTR-ADJ-NEG -37/-1.2V TO-220 PKG	00000	LT337AT
U3	1820-2182	1	ANALOG MULTIPLEXER 4 CHNL 16 -DIP-P	28480	1820-2182
U4	1826-1403		IC V RGLTR-ADJ-POS 3/40V	00000	LT317AT
U5	1826-1670		IC V RGLTR-ADJ-NEG -37/-1.2V TO-220 PKG	00000	LT337AT
U6	1826-1381	3	IC OP AMP LOW-BIAS-H-IMPDP 8-DIP-P PKG	00000	LT1012CN8
U7	1826-1381		IC OP AMP LOW-BIAS-H-IMPDP 8-DIP-P PKG	00000	LT1012CN8
U8	1826-1381		IC OP AMP LOW-BIAS-H-IMPDP 8-DIP-P PKG	00000	LT1012CN8
U9	1820-3177	1	IC MUXR/DATA-SEL CMOS/74HC 2-T0-1-LINE	04713	MC74HC157N
U10	1826-0774	1	IC V RGLTR-V-REF-FXD 1.22/1.24V TO-92	27014	LM385BZ-1.2
U11	1826-0635	1	IC OP AMP LOW-OFS 8-DIP-P PKG	06665	OP-07CP
VR1	1902-0951	1	DIODE-ZNR 5.1V 5% DO-35 PD=.4W TC=+.035%	28480	1902-0951
W1	01141-61602	1	CABLE ASSEMBLY		Safety Ground

**1142A Probe Control and Power Module
Replaceable Parts**

Table 9 Component Location on A1 Assembly

Ref Des	Grid Loc	Ref Des	Grid Loc	Ref Des	Grid Loc	Ref Des	Grid Loc	Ref Des	Grid Loc	Ref Des	Grid Loc	Ref Des	Grid Loc	Ref Des	Grid Loc
C1	C-2	C17	C-6	CR10	C-5	J1	G-7	R5	B-6	R22	B-3	R45	C-3	U5	D-6
C2	F-3	C18	B-5	CR11	C-3	J2	B-7	R6	B-6	R23	B-5	R46	C-3	U6	B-3
C3	H2	C19	B-6	CR12	C-6	J3	C-7	R7	C-4	R24	B-5	R47	C-2	U7	C-3
C4	J-3	C20	B-5	CR13	C-3			R8	C-5	R25	B-2	R48	D-3	U8	B-3
C5	C-3	C21	B-5	CR14	C-6	MP1	H-1	R9	C-4	R26	B-2			U9	A-5
C6	C-5	C22	B-6	CR17	B-5	MP2	E-3	R10	C-5	R27	A-5	RP1	B-3	U10	C-2
C7	B-3	C23	B-4	CR18	B-6	MP3	D-3	R11	C-5	R28	A-5			U11	C-3
C8	C-5	C24	B-6			MP4	E-5	R12	C-5	R29	B-6	S1	H-7		
C9	C-5	C25	B-4	DS1	G-2	MP7	E-4	R13	E-3	R30	B-6	S2	E-2	VR1	E-3
C10	C-5	C26	G-6			MP8	G-4	R14	C-4	R31	B-3				
C11	E-3			E1	F-6	MP9	G-4	R15	C-4	R32	B-2	T1	H-5		
C12	A-3	CR2	F-3	E2	E-6			R16	C-4	R40	C-2				
C13	A-3	CR3	F-3			P1	E-7	R17	C-6	R41	A-2	U1	D-4		
C14	B-3	CR5	C-3	F1	E-6			R18	C-6	R42	C-2	U2	D-5		
C15	A-3	CR6	C-5			R3	A-6	R19	C-6	R43	C-2	U3	A-2		
C16	C-4	CR9	C-3	HS1	D-5	R4	A-6	R21	B-3	R44	C-3	U4	D-3		

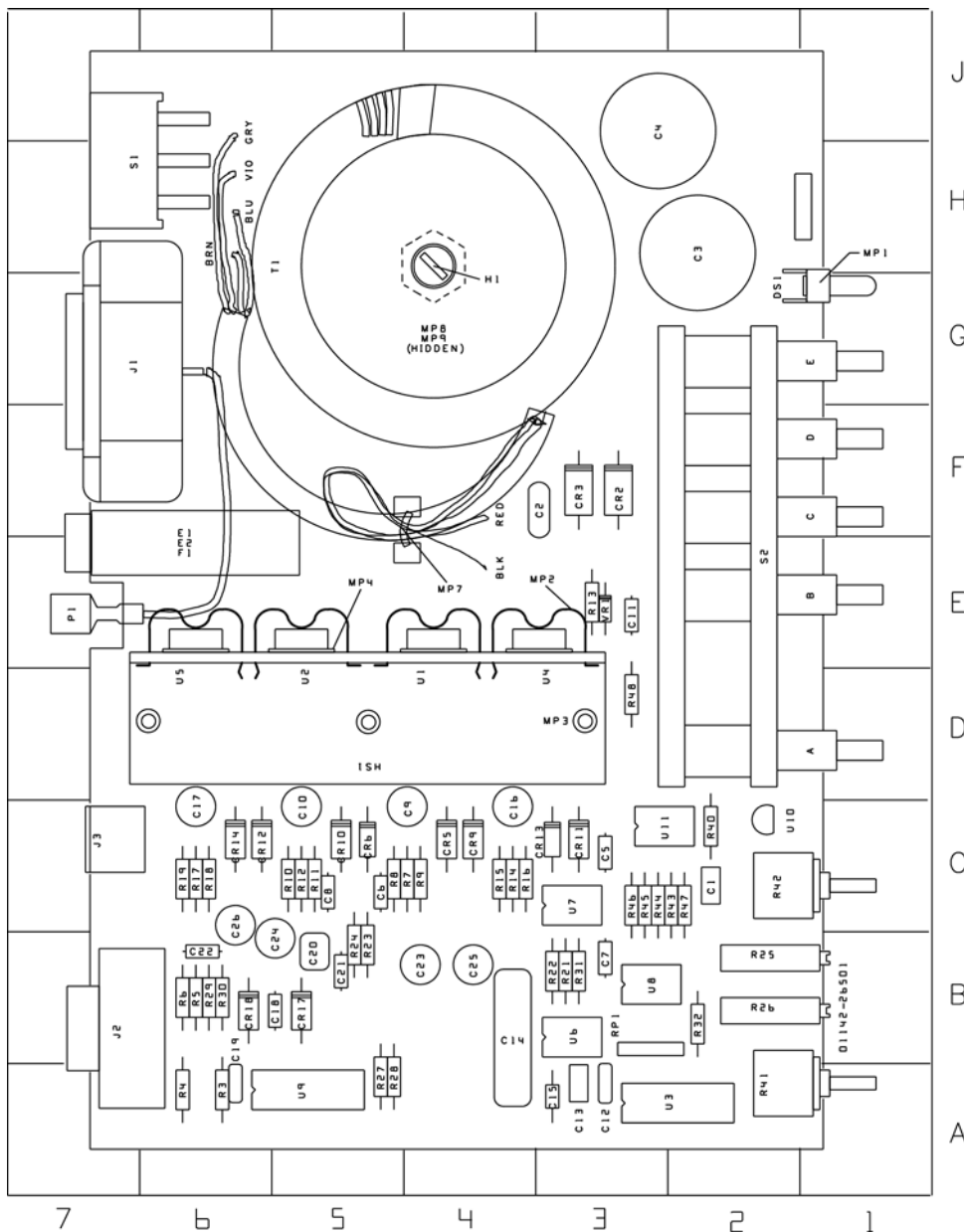

Figure 6 A1 Power and Control Assembly

Schematics





Schematics are sequentially numbered in the figure title at the bottom of the page. Schematic numbers are used to cross reference signal connections between the schematics.

Table 11 on page 30 lists the power connections, power grounds, and non-functional pins of ICs (integrated circuits) that are on Figure 8 on page 30. This helps avoid non-functional clutter on the schematic and gives one place to show IC power connections when IC sections are split between schematics.

Unless otherwise noted, the following component values apply:

- Resistance is in ohms.
- Capacitance is in picofarads.
- Inductance is in microhenries.

Table 10 Additional Schematic Symbols

Symbol	Description
	Tool-aided adjustment.
	Numbered test point. Measurement aid provided.
	Lettered test point. No measurement aid provided.
	Signal reference.
15	Schematic reference.

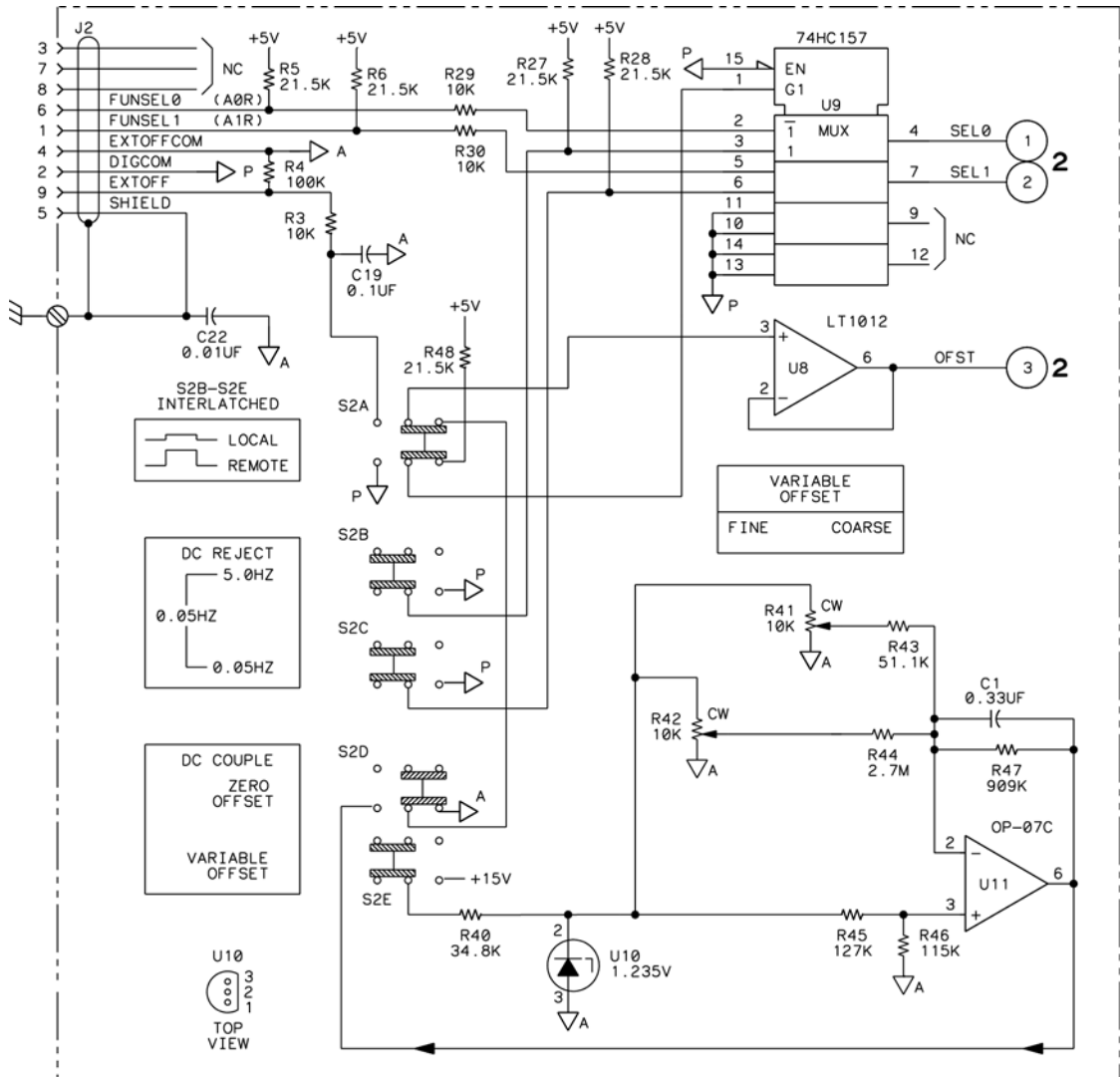

Figure 7 Schematic 1

1142A Probe Control and Power Module
Replaceable Parts

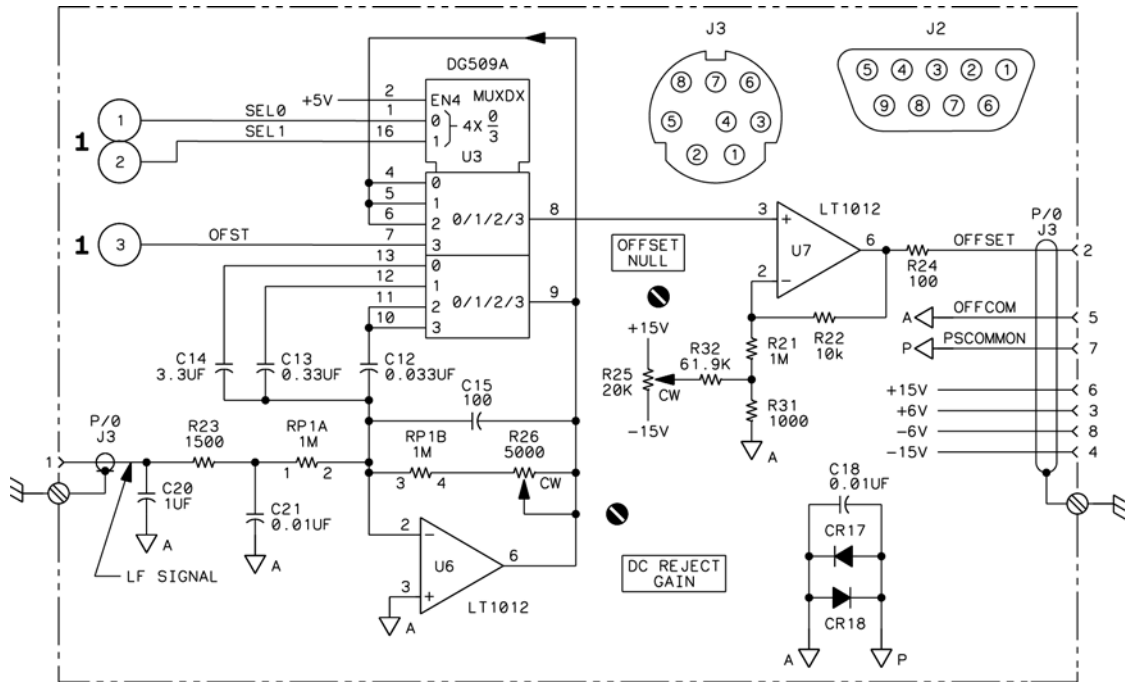

Figure 8 Schematic 2

Table 11 IC Connections Not Shown (for Figure 7)

Supply	Pin Number	IC Group
+15V	14	U3
-15V	3	
GND	15	
+15V	7	U6 - 8, 11
-15V	4	
NC	1, 5, 8	
+5	16	U9
GND	8	

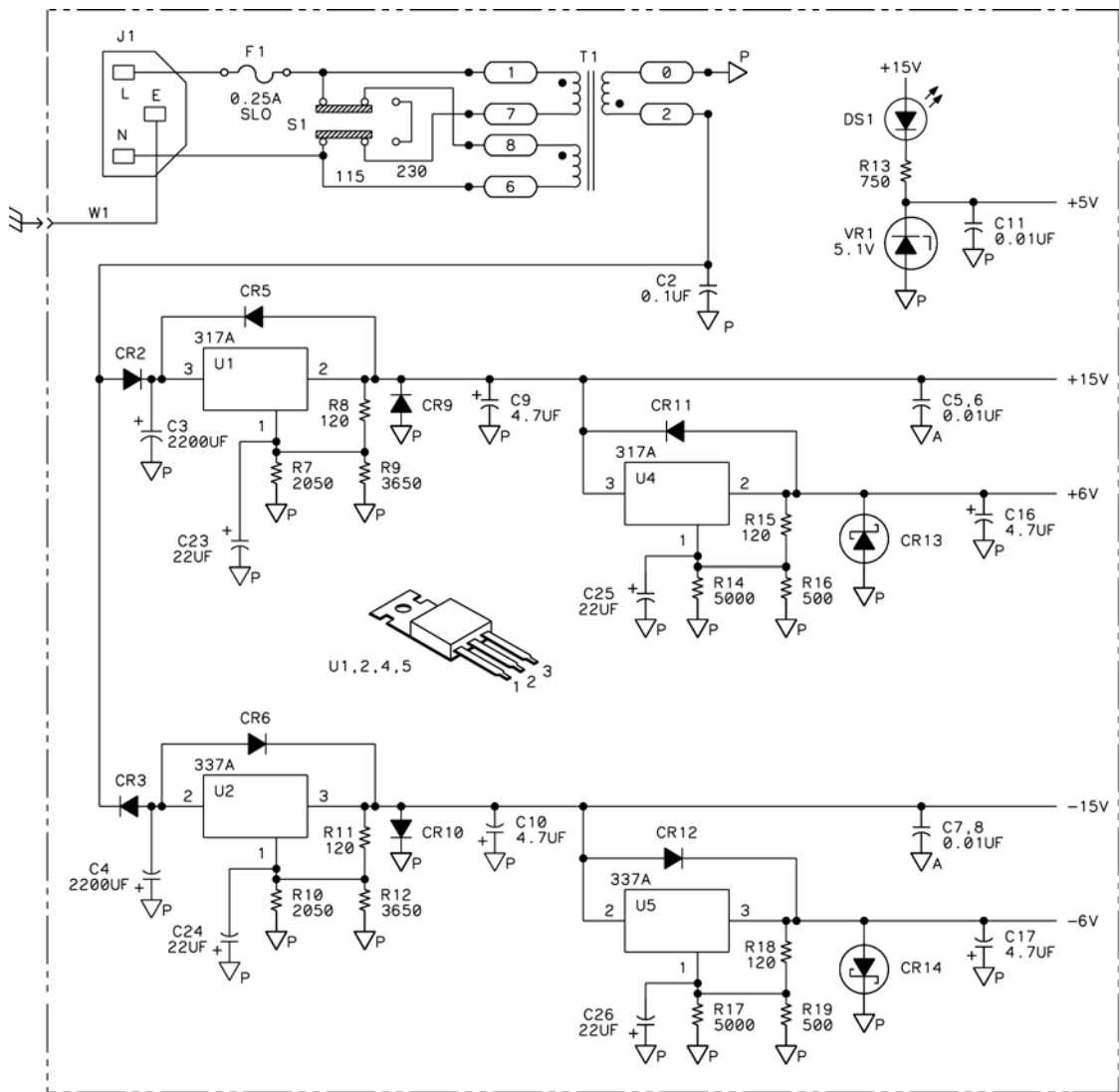

Figure 9 Schematic 3

Contacting Agilent

Agilent Technologies contact information can be found at:

www.agilent.com/find/contactus

When returning the product, observe the following tips:

- Write the following information on a tag and attach it to the power supply.
 - Name and address of the owner
 - Power supply model number
 - Description of service required or failure indications
- Retain all accessories.
- Return the power supply in its original shipping materials or pack the power supply in foam or other shock-absorbing material and place it in a strong shipping container. If the original shipping materials are not available, place 3 to 4 inches of shock-absorbing material around the instrument and place it in a box that does not allow movement during shipping.
- Seal the shipping container securely.
- Mark the shipping container as FRAGILE. In all correspondence, refer to the instrument by model number and full serial number.

Manual Part Number
01142-97003



Agilent Technologies
Printed in Malaysia, August 2014