

Keysight N2818/9A Differential Probes

User's Guide

Notices

© Keysight Technologies 2014, 2015, 2016, 2020, 2022

No part of this manual may be reproduced in any form or by any means (including electronic storage and retrieval or translation into a foreign language) without prior agreement and written consent from Keysight Technologies as governed by United States and international copyright laws.

Manual Part Number

N2818-97004

Edition

Edition 6, May 2022

Available in electronic format only

Published by:

Keysight Technologies
1400 Fountaingrove Parkway
Santa Rosa, CA, 95403

Warranty

THE MATERIAL CONTAINED IN THIS DOCUMENT IS PROVIDED "AS IS," AND IS SUBJECT TO BEING CHANGED, WITHOUT NOTICE, IN FUTURE EDITIONS. FURTHER, TO THE MAXIMUM EXTENT PERMITTED BY APPLICABLE LAW, KEYSIGHT DISCLAIMS ALL WARRANTIES, EITHER EXPRESS OR IMPLIED WITH REGARD TO THIS MANUAL AND ANY INFORMATION CONTAINED HEREIN, INCLUDING BUT NOT LIMITED TO THE IMPLIED WARRANTIES OF MERCHANTABILITY AND FITNESS FOR A PARTICULAR PURPOSE. KEYSIGHT SHALL NOT BE LIABLE FOR ERRORS OR FOR INCIDENTAL OR CONSEQUENTIAL DAMAGES IN CONNECTION WITH THE FURNISHING, USE, OR PERFORMANCE OF THIS DOCUMENT OR ANY INFORMATION CONTAINED HEREIN. SHOULD KEYSIGHT AND THE USER HAVE A SEPARATE WRITTEN AGREEMENT WITH WARRANTY TERMS COVERING THE MATERIAL IN THIS DOCUMENT THAT CONFLICT WITH THESE TERMS, THE

WARRANTY TERMS IN THE SEPARATE AGREEMENT WILL CONTROL.

Technology Licenses

The hardware and/or software described in this document are furnished under a license and may be used or copied only in accordance with the terms of such license.

U.S. Government Rights

The Software is "commercial computer software," as defined by Federal Acquisition Regulation ("FAR") 2.101. Pursuant to FAR 12.212 and 27.405-3 and Department of Defense FAR Supplement ("DFARS") 227.7202, the U.S. government acquires commercial computer software under the same terms by which the software is customarily provided to the public. Accordingly, Keysight provides the Software to U.S. government customers under its standard commercial license, which is embodied in its End User License Agreement (EULA), a copy of which can be found at <http://www.keysight.com/find/sweula>. The license set forth in the EULA represents the exclusive authority by which the U.S. government may use, modify, distribute, or disclose the Software. The EULA and the license set forth therein, does not require or permit, among other things, that Keysight: (1) Furnish technical information related to commercial computer software or commercial computer software documentation that is not customarily provided to the public; or (2) Relinquish to, or otherwise provide, the government rights in excess of these rights customarily provided to the public to use, modify, reproduce, release, perform, display, or disclose commercial computer software or commercial computer software documentation. No additional government requirements beyond those set forth in the EULA shall apply, except to the extent that those terms, rights, or licenses are explicitly required from all providers of commercial computer software pursuant to the FAR and the DFARS and are set forth specifically in

writing elsewhere in the EULA. Keysight shall be under no obligation to update, revise or otherwise modify the Software. With respect to any technical data as defined by FAR 2.101, pursuant to FAR 12.211 and 27.404.2 and DFARS 227.7102, the U.S. government acquires no greater than Limited Rights as defined in FAR 27.401 or DFAR 227.7103-5 (c), as applicable in any technical data. 52.227-14 (June 1987) or DFAR 252.227-7015 (b)(2) (November 1995), as applicable in any technical data.

Safety Notices

CAUTION

A **CAUTION** notice denotes a hazard. It calls attention to an operating procedure, practice, or the like that, if not correctly performed or adhered to, could result in damage to the product or loss of important data. Do not proceed beyond a **CAUTION** notice until the indicated conditions are fully understood and met.

WARNING

A **WARNING** notice denotes a hazard. It calls attention to an operating procedure, practice, or the like that, if not correctly performed or adhered to, could result in personal injury or death. Do not proceed beyond a **WARNING** notice until the indicated conditions are fully understood and met.

Contents

Introduction	5
Oscilloscope Compatibility	6
Handling the Probe	6
Channel Identification Rings	7
To Clean the Probe	7
Inspecting the Probe	7
Accessories	8
N2818A	8
N2819A	10
Using the N2818A Probe	12
Connecting the Extreme Temperature Probing Kit to the Probe	13
Using the N2819A Probe	16
Single and Variable Pitch Signal Pins	17
Extension Leads	18
Micro IC Clips and Pincer Clips	18
DC Blocking Capacitor	18
Probe Offset Adjustment	19
Safety Information	21
Specifications and Characteristics	25
N2818A Performance Plots	28
N2819A Performance Plots	32
N2818A Performance Verification	36
Scope Vertical Accuracy	37
DC Differential Gain	37
Bandwidth	38

Contents

N2819A Performance Verification	40
Scope Vertical Accuracy	40
DC Differential Gain	41
Bandwidth	41
Returning the Probe for Service	44
Contacting Keysight Technologies	44

Index

Keysight N2818/9A Differential Probes

User Guide

Introduction

The N2818A and N2819A differential probes provide superior general-purpose differential signal measurements that are required for high-speed power measurements, vehicle bus measurements, and high-speed digital system designs.

CAUTION

Before using the probe, refer to "Safety Information" on page 21.

Table 1 Quick Probe Comparison

	N2818A without N7013/14A Extreme Temperature Probing Kit	N2818A with N7013/14A Extreme Temperature Probing Kit	N2819A
Bandwidth	200 MHz	70 MHz	800 MHz
Attenuation Ratio	10:1	10:1	10:1
Input Resistance	1 M Ω	1 M Ω	200 k Ω
Input Capacitance	3.5 pF	3.5 pF	1 pF



N2818A Probe

N2819A Probe

Figure 1 Probes (Accessories Not Shown)

Oscilloscope Compatibility

The N2818A and N2819A probes are compatible with the Keysight oscilloscopes shown in [Table 2](#). Up to four probes can be connected to the oscilloscope at the same time. The table also lists the minimum required firmware version for the oscilloscope.

NOTE

The N2818A and N2819A probes are designed for oscilloscopes with 50Ω AutoProbe-interface channel inputs. The AutoProbe interface provides the power to the probe.

Is Your Oscilloscope Software Up-to-Date? Keysight periodically releases software updates to support your probe, fix known defects, and incorporate product enhancements. To download the latest firmware, go to www.keysight.com and search for your oscilloscope's topic. Click on the "Drivers, Firmware & Software" tab.

Table 2 Compatible Oscilloscopes and Support

Oscilloscope	Required Firmware Version	Adapter Required
Infiniium Oscilloscopes		
90000 Q-Series	≥ 4.30	N5442A
90000 X-Series	≥ 4.30	N5442A
90000A	≥ 4.30	–
9000 H-Series	≥ 4.30	–
9000A-Series	≥ 4.30	–
InfiniVision Oscilloscopes		
4000 X-Series	≥ 3.20	–
3000 X-Series	≥ 2.35	–

Handling the Probe

Handle the probe with care and refer to the safety notices in this manual. Note that the probe cable and the extreme temperature extension cables are sensitive parts and, therefore, you should be careful not to damage them through excessive bending or pulling. You should also avoid any mechanical shocks to this probe in order to guarantee accurate performance and protection.

CAUTION

Always wear an ESD wrist strap when working with active probes. Not doing so can result in the probe becoming permanently damaged.

Channel Identification Rings

When multiple probes are connected to the oscilloscope, use the channel identification rings to associate the channel inputs with each probe. Place one colored ring near the probe's channel connector and place an identical color ring near the probe head.

To Clean the Probe

Disconnect the probe from the oscilloscope and clean the probe with a soft cloth dampened with a mild soap and water solution. Make sure that the probe is completely dry before reconnecting it to an oscilloscope. Avoid using abrasive cleaners and chemicals containing benzene or similar solvents.

Inspecting the Probe

- Inspect the shipping container for damage.
Keep the damaged shipping container or cushioning material until the contents of the shipment have been checked for completeness and the probe has been checked mechanically and electrically.
- Check the accessories.
- If the contents are incomplete or damaged, notify your Keysight Technologies Sales Office.
- Inspect the probe. If there is mechanical damage or defect, or if the probe does not operate properly, notify your Keysight Technologies Sales Office.

If the shipping container is damaged, or the cushioning materials show signs of stress, notify the carrier as well as your Keysight Technologies Sales Office. Keep the shipping materials for the carrier's inspection. The Keysight Technologies office will arrange for repair or replacement at Keysight Technologies' option without waiting for claim settlement.

Accessories

N2818A

Supplied Accessories

The N2818A probe comes with the accessories shown in [Figure 2](#). These accessories are not compatible with N2819A probes. Replacements can be ordered with the N2792-68700 replacement kit. The quantity for each accessory in the kit is the same as listed in [Table 3](#) and originally provided with the probe.

WARNING

The measurement category of a combination of a PROBE ASSEMBLY and an accessory is the lower of the measurement categories of the PROBE ASSEMBLY and of the accessory.



Figure 2 N2818A Supplied Accessories

Table 3 N2818A Supplied Accessories

Accessory	Qty
Hook Clip (Black)	1
Hook Clip (Red)	1
Alligator Clip (Black)	1
Alligator Clip (Red)	1
Offset Adjustment Tool	1

Optional Accessories

For extreme temperature probing, you can order the N7013/14A extreme temperature probing kit separately. This extreme temperature probing kit is not compatible with N2819A probes. The quantity for each accessory in the kit is the same as listed in [Table 4](#).

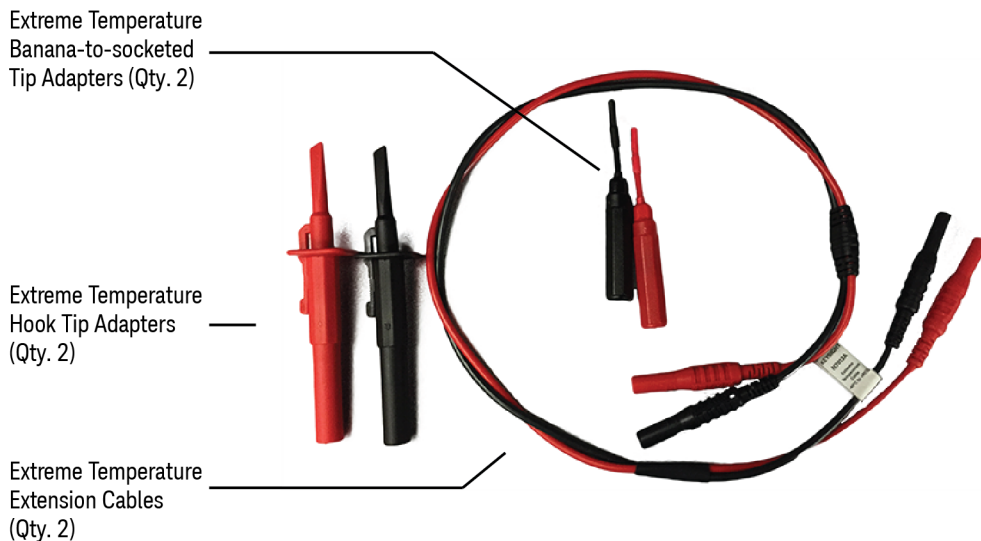

Figure 3 N2818A Optional Accessories (Extreme Temperature Probing Kit)

Table 4 N2818A Optional Accessories

Accessory	Qty
Extreme Temperature Hook Tip Adapters (Black)	1
Extreme Temperature Hook Tip Adapters (Red)	1
Extreme Temperature Differential Extension Cables (Black)	1
Extreme Temperature Differential Extension Cables (Red)	1
Extreme Temperature Banana-to-Socketed Tip Adapters for connecting to 0.025" square pins (Black)	1
Extreme Temperature Banana-to-Socketed Tip Adapters for connecting to 0.025" square pins (Red)	1

N2819A

The N2819A probe comes with the accessories shown in [Figure 4](#) and listed in [Table 5](#) on page 11. These accessories are not compatible with N2818A probes. Replacements can be ordered with the N2793-68700 replacement kit. The quantity for each accessory in the kit is the same as listed in the table and originally provided with the probe.

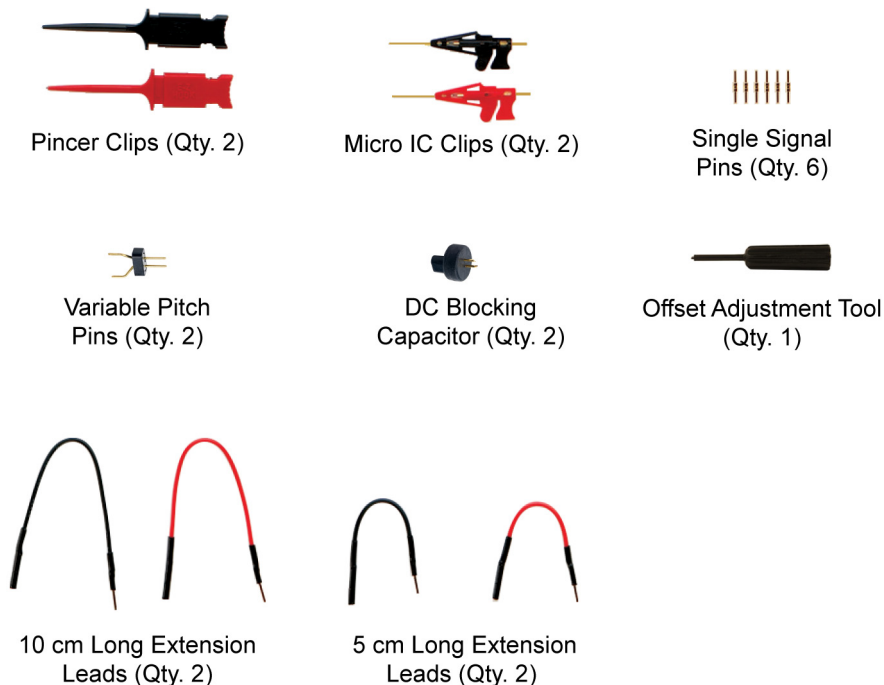

Figure 4 N2819A Supplied Accessories

Table 5 N2819A Supplied Accessories

Accessory	Qty
Pincer Clip (red)	1
Pincer Clip (black)	1
Micro IC Clip (red)	1
Micro IC Clip (black)	1
Extension Lead, 0.8 mm J-P, 5 cm long (red)	1
Extension Lead, 0.8 mm J-P, 5 cm long (black)	1
Extension Lead, 0.8 mm J-P, 10 cm long (red)	1
Extension Lead, 0.8 mm J-P, 10 cm long (black)	1
Single Signal Pin, 8 mm long	6
DC Blocking Capacitor	2
Variable Pitch Spacing Adapter	2
Offset Adjustment Tool	1

Using the N2818A Probe

Before you can use the N2818A probe, gently push the supplied hook clips or alligator clips onto the probe leads as shown in [Figure 5](#). Use the hook clips to clamp onto smaller components and the alligator clips to clamp onto thicker gauge devices.

WARNING

Must be Grounded. Before making connections to the input leads of this probe, ensure that the probe's output connector is attached to the channel input of the oscilloscope and the oscilloscope is properly grounded.



CAUTION

To protect against electrical shock, use only the accessories supplied with this probe or in the accessory kit.

CAUTION

This probe is to carry out differential measurements between two points on the circuit under test. This probe is not for electrically insulating the circuit under test and the measuring instrument.

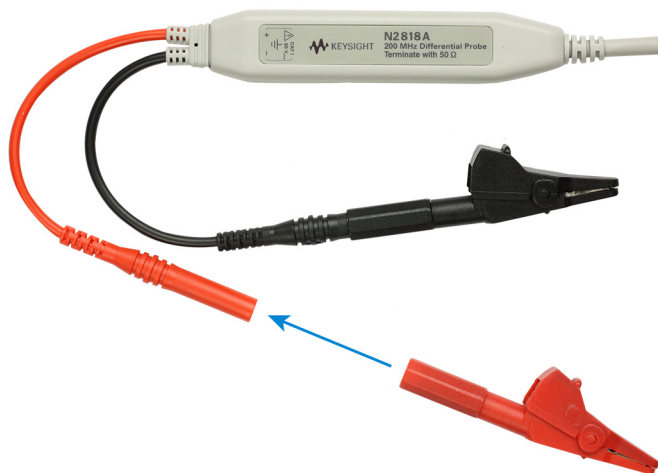

Figure 5 Inserting the Supplied Clips

Connecting the Extreme Temperature Probing Kit to the Probe

For extreme temperature probing, you can connect the N7013/14A extreme temperature probing kit with the probe.

NOTE

The N7013/14A extreme temperature probing kit is not supplied with the probe. You can order this kit separately.

The N7013A extreme temperature probing kit includes:

- One pair of extreme temperature differential extension cables (black and red)
- One pair of extreme temperature hook tip adapters (black and red)
- One pair of extreme temperature banana-to-socketed tip adapters for connecting to 0.025" square pins (black and red)

The N7014A extreme temperature probing kit includes:

- One pair of extreme temperature banana-to-socketed tip adapters for connecting to 0.025" square pins (black and red)

CAUTION

Only the extension cables and the tip adapters provided with the cables are rated to extreme temperatures. The differential probe, original cables, and original accessories should not be exposed to extreme temperatures. When probing with the extension cables the bandwidth performance will be reduced, see [Table 6](#) on page 25.

Perform the following steps to connect the N7013/14A extreme temperature kit to the N2818A probe:

- 1 Connect the red and black extreme temperature differential extension cables to the existing probe cables.

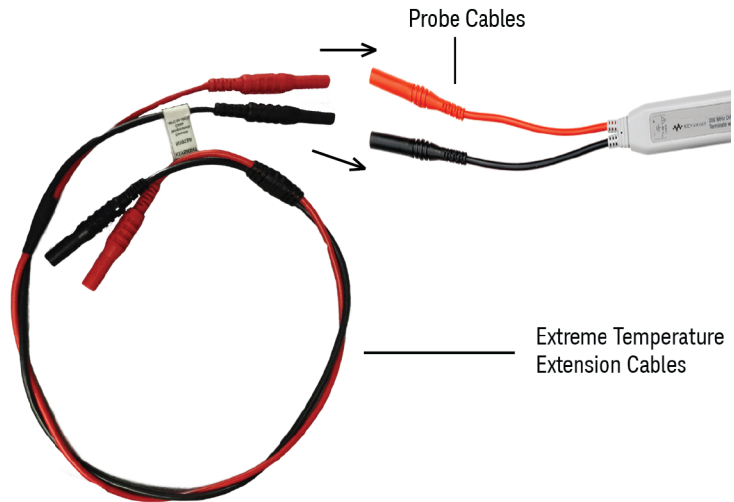

Figure 6 Connecting the Extreme Temperature Differential Extension Cables

- 2 Connect the red and black extreme temperature hook tip adapters to the extreme temperature differential extension cables which are already connected to the existing probe cables.

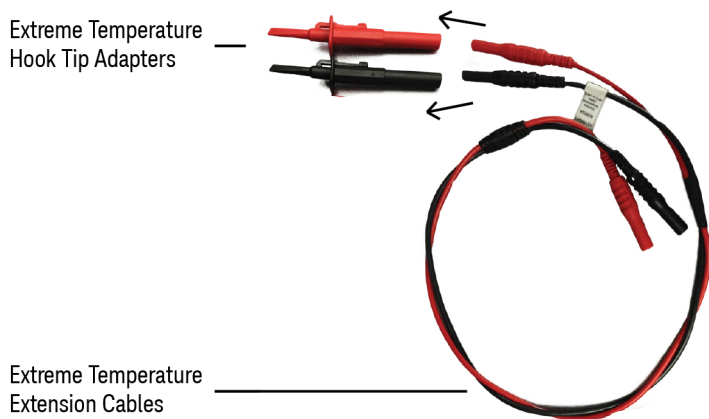

Figure 7 Connecting the Extreme Temperature Hook Tip Adapters

Or,

Connect the red and black extreme temperature banana-to-socketed tip adapters to the extreme temperature differential extension cables which are already connected to the existing probe cables.

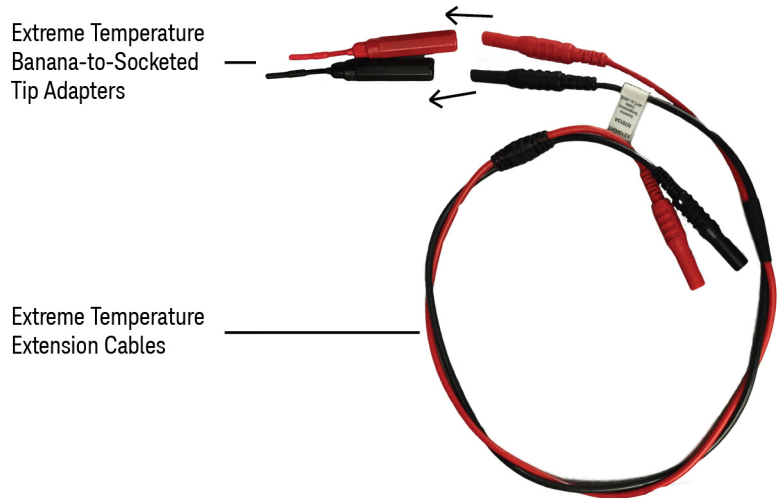

Figure 8 Connecting the Extreme Temperature Banana-to-Socketed Tip Adapters

Using the N2819A Probe

Before using the N2819A probe, attach the supplied probing accessories to connect the probe inputs to the circuit under test. Figure 9 shows the options for connecting the supplied clips, leads, and pins. Gently press the probing accessories into the end of the probe's tip. A label on the probe tip identifies the probe's positive and negative leads.

WARNING

Must be Grounded. Before making connections to the input leads of this probe, ensure that the probe's output connector is attached to the channel input of the oscilloscope and the oscilloscope is properly grounded.

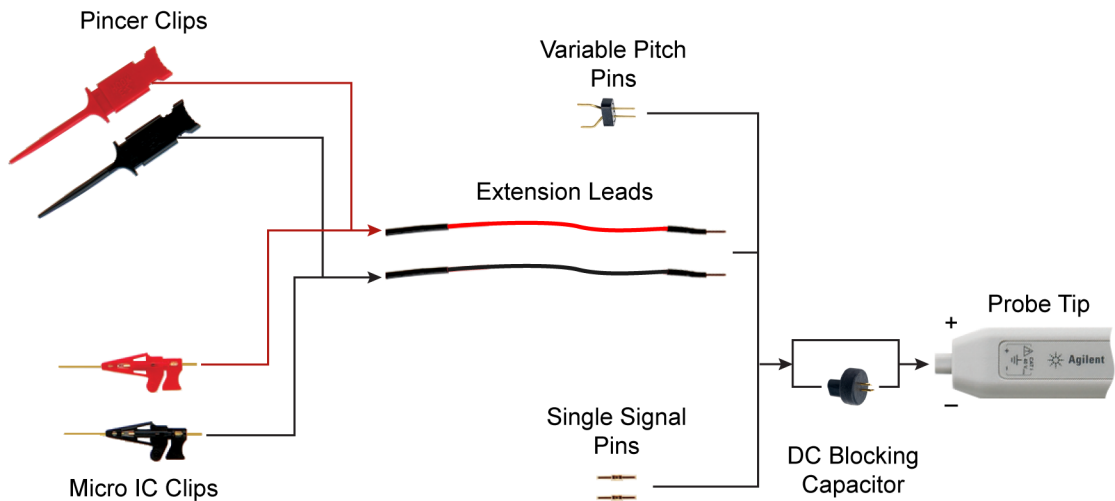

Figure 9 Probe Clip, Lead, and Pin Connections

CAUTION

To protect against electrical shock, use only the accessories supplied with this probe or in the accessory kit.

CAUTION

This probe is designed to perform differential measurements between two points on the circuit under test. This probe is not for electrically insulating the circuit under test and the measuring instrument.

Single and Variable Pitch Signal Pins

Insert the single signal pins into the probe tip as shown in [Figure 10](#). Directly probing with these pins results in the best possible signal integrity when compared to the other probing accessories.

NOTE

The single signal pins are symmetrical. Either end of the pin may be inserted into the probe tip.

Two Single Signal Pins



Figure 10 Signal Pins Inserted into the Probe Tip

[Figure 11](#) shows the variable pitch pins inserted into the probe tip. Gently rotate the pins to change the distance between the pins.



Figure 11 Variable Pitch Pins Inserted into the Probe Tip

Extension Leads

If the length of the pins is not adequate for your measurement setup or if you need to use the pincer or micro IC clips, the extension leads can be placed over the pins as shown below. The probe comes with both 5 cm and 10 cm long extensions leads.

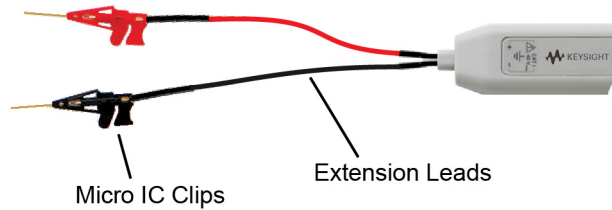

Figure 12 Extension Leads on Probe

Micro IC Clips and Pincer Clips

Use the micro IC and pincer clips to probe miniature IC and components. These clips attach to the end of the extension jaws leads. Squeeze the lever on the micro IC clips to extend the grasping jaws. Push the back of the pincer clips to extend their connectors.

DC Blocking Capacitor

Use the DC blocking capacitor to block out unwanted DC components on the input signal.



Figure 13 DC Blocking Capacitor Inserted into the Probe Tip

Probe Offset Adjustment

The N2818A/19A differential probes can be adjusted for zeroing out the probe's offset voltage using the trimmer tool supplied with the probe. Follow the procedure described below to perform the offset zero calibration.

NOTE

Allow the oscilloscope and probe to warm up for 20 minutes before performing the adjustment.

- 1 Connect the probe to an oscilloscope channel input. Turn on the oscilloscope and wait for 20 minutes to allow the oscilloscope and probe to warm up.
- 2 If the oscilloscope needs calibration, perform a user calibration before the probe calibration.
- 3 Using the probe's connection accessories, short the + and - inputs together.
- 4 Press Default setup and Autoscale of the oscilloscope.
- 5 Press the channel button for the probe and set the oscilloscope channel to DC coupled mode.
- 6 Set the oscilloscope to Averaging mode (x8 or higher) to reduce oscilloscope noise, if needed.
- 7 Set the vertical scale of the oscilloscope to 100 mV/div.
- 8 Using the offset adjustment tool that comes with the probe, adjust the probe offset voltage to zero volts.

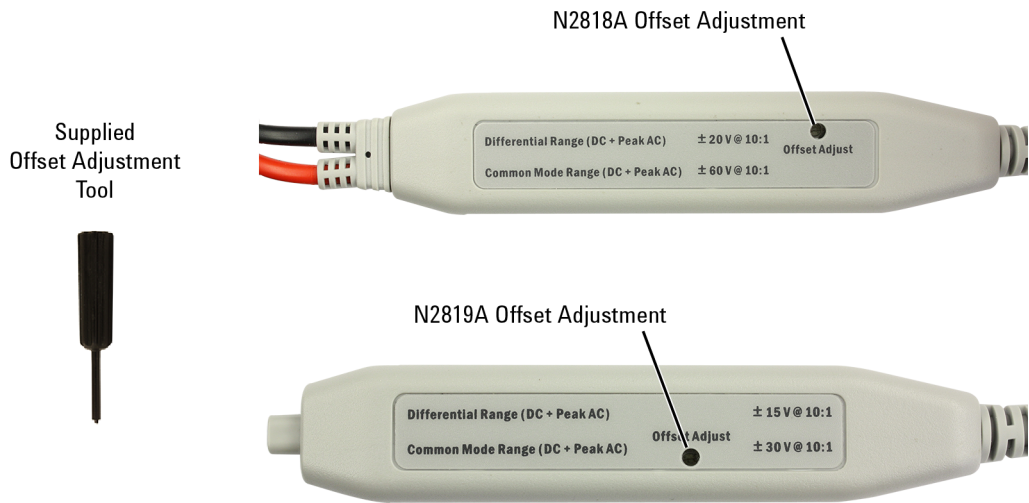

Figure 14 Location of the Offset Adjustment

Safety Information



This manual provides information and warnings essential for operating this probe in a safe manner and for maintaining it in safe operating condition. Before using this equipment and to ensure safe operation and to obtain maximum performance from the probe, carefully read and observe the following warnings, cautions, and notes.

This product has been designed and tested in accordance with accepted industry standards, and has been supplied in a safe condition. The documentation contains information and warnings that must be followed by the user to ensure safe operation and to maintain the product in a safe condition.

Note the external markings on the probe that are described in this document.

WARNING

To avoid personal injury and to prevent fire or damage to this product or products connected to it, review and comply with the following safety precautions. Be aware that if you use this probe assembly in a manner not specified, the protection this product provides may be impaired.

WARNING

Observe Maximum Working Voltage. To avoid injury, do not use the N2818A probe above 60V between each input lead and earth or between the two input leads and do not use the N2819A probe above 40V between each input lead and earth or between the two input leads.

WARNING

Must be Grounded. Before making connections to the input leads of this probe, ensure that the probe is connected to the oscilloscope's channel input and the oscilloscope is properly grounded.

WARNING

The measurement category of a combination of a PROBE ASSEMBLY and an accessory is the lower of the measurement categories of the PROBE ASSEMBLY and of the accessory.

WARNING

Do Not Operate Without Covers. To avoid electrical shock or fire hazard, do not operate this probe with the covers removed.

WARNING

Do Not Operate in Wet / Damp Conditions. To avoid electrical shock, do not operate this probe in wet or damp conditions.

WARNING

Do Not Operate in an Explosive Atmosphere. To avoid injury or fire hazard, do not operate this probe in an explosive atmosphere.

WARNING

Avoid Exposed Circuit. To avoid injury, remove jewelry such as rings, watches, and other metallic objects. Do not touch exposed connections and components when power is present.

WARNING

For Indoor Use Only. Only use this probe indoors.

WARNING

Do Not Operate With Suspected Failures. If you suspect there is damage to this probe, have it inspected by a qualified service personnel.

WARNING

Connect and Disconnect Properly. Connect the probe to the oscilloscope and connect the ground lead to earth ground before connecting the probe to the circuit under test. Disconnect the probe input and the probe ground lead from the circuit under test before disconnecting the probe from the oscilloscope.

WARNING

Do not use a probe which is cracked, damaged or has defective leads.

WARNING

Do not install substitute parts or perform any unauthorized modification to the probe.

WARNING

Do not use the probe or oscilloscope in a manner not specified by the manufacturer.

CAUTION

The probe cable and the extreme temperature extension cables are sensitive parts and, therefore, you should be careful not to damage them through excessive bending or pulling. Avoid any mechanical shocks to this product in order to guarantee accurate performance and protection.

Concerning the Oscilloscope or Voltage Measuring Instrument to Which the Probe is Connected

WARNING

Whenever it is likely that the ground protection is impaired, you must make the instrument inoperative and secure it against any unintended operation.

WARNING

If you energize the instrument by an auto transformer (for voltage reduction or mains isolation), the ground pin of the input connector terminal must be connected to the earth terminal of the power source.

WARNING

Before turning on the instrument, you must connect the protective earth terminal of the instrument to the protective conductor of the (mains) power cord. The mains plug shall only be inserted in a socket outlet provided with a protective earth contact. You must not negate the protective action by using an extension cord (power cable) without a protective conductor (grounding). Grounding one conductor of a two-conductor outlet is not sufficient protection.

WARNING

Only fuses with the required rated current, voltage, and specified type (normal blow, time delay, etc.) should be used. Do not use repaired fuses or short-circuited fuse holders. To do so could cause a shock or fire hazard.

WARNING

Capacitors inside the instrument may retain a charge even if the instrument is disconnected from its source of supply.

Specifications and Characteristics

The following tables list the characteristics for the N2818A and N2819A differential probes. Before any testing and to allow the probe to warm up, connect the probe to a powered-on oscilloscope for at least 20 minutes. Ensure that the environmental conditions do not exceed the probe's specified limits.

Table 6 Electrical Specifications and Characteristics

Description	N2818A without the N7013/14A Extreme Temperature Probing Kit*	N2818A with the N7013/14A Extreme Temperature Probing Kit	N2819A
Bandwidth (-3 dB) †	200 MHz	70 MHz	800 MHz
Attenuation Ratio	10:1	10:1	10:1
Probe Risetime (10% - 90%)	1.75 ns	1.75 ns	437 ps
Gain Accuracy (% of reading) †	±2%	±2%	±2%
Absolute Maximum Rated Input Voltage (each side to ground)	±60V	±60V	±40V
Maximum Differential Input Voltage (DC + AC Peak)	±20V	±20V	±15V
Maximum Common Mode Input Voltage	±60V	±60V	±30V
Input Resistance Capacitance			
Each Side to Ground:	500 kΩ 7 pF	500 kΩ 7 pF	100 kΩ 2 pF
Between Inputs:	1 MΩ 3.5 pF	1 MΩ 3.5 pF	200 kΩ 1 pF
Output Voltage Swing	±2V (driving 50Ω scope input)	±2V (driving 50Ω scope input)	±1.5V (driving 50Ω scope input)
Offset (typical)	±2 mV	±2 mV	±5 mV
Offset Adjustment Range	-95 mV to +95 mV	-95 mV to +95 mV	-20 mV to +20 mV
AC CMRR	> -80 dB at 60 Hz > -50 dB at 10 MHz 6 mV _{rms}	> -80 dB at 60 Hz > -50 dB at 10 MHz 6 mV _{rms}	> -60 dB at 60 Hz > -15 dB at 500 MHz 4.7 mV _{rms}
Noise Referenced to Input, Probe Only	6 mV _{rms}	6 mV _{rms}	4.7 mV _{rms}
Power Requirements	AutoProbe Interface	AutoProbe Interface	AutoProbe Interface

* All entries are typical unless otherwise noted.

† Warranted Specification.

Table 7 Environmental Specifications

Description	Specification
Temperature	Operating: -10 °C to +40 °C (Probe without the N7013/14A extreme temperature probing kit) Operating: -40 °C to +85 °C (Probe with the N7013/14A extreme temperature probing kit) Nonoperating: -30 °C to +70 °C
Altitude	Operating: 3,000 m (9,842 feet) Nonoperating: 15,300 m (50,196 feet)
Humidity	Operating: 25 - 85% room humidity Nonoperating: 25 - 85% room humidity
Pollution Degree	Pollution Degree 2

Table 8 N2818/9A Safety Specifications

Description
CEI/IEC 61010-031 CAT II

Table 9 Mechanical Characteristics

Description	N2818A	N2819A
Approximate Weight (not including accessories)	170g (6 oz)	170g (6 oz)
BNC Cable Length	120 cm (47 inches)	120 cm (47 inches)
Length of Input Leads	15 cm (5.9 inches)	N/A
Length of Extreme Temperature Extension Cables	70 cm (27.5 inches)	N/A
Housing Dimensions (L x W x H)	111 mm x 22 mm x 14 mm (4.4 in x 0.9 in x 0.6 in)	111 mm x 22 mm x 14 mm (4.4 in x 0.9 in x 0.6 in)

Table 10 DC Blocking Capacitor Electrical Characteristics

Description	Characteristic (All Are Typical)
Bandwidth (-3 dB)	30 kHz to 1 GHz
Impedance	50 Ω
Maximum Input Range	100V
Insertion Loss (30 kHz to 1 GHz)	1.0 dB maximum
VSWR (30 kHz to 1 GHz)	1.35:1 maximum
Operating Temperature Range	-25 °C to +85 °C
Compatibility	With the N2819A and probe accessories

N2818A Performance Plots

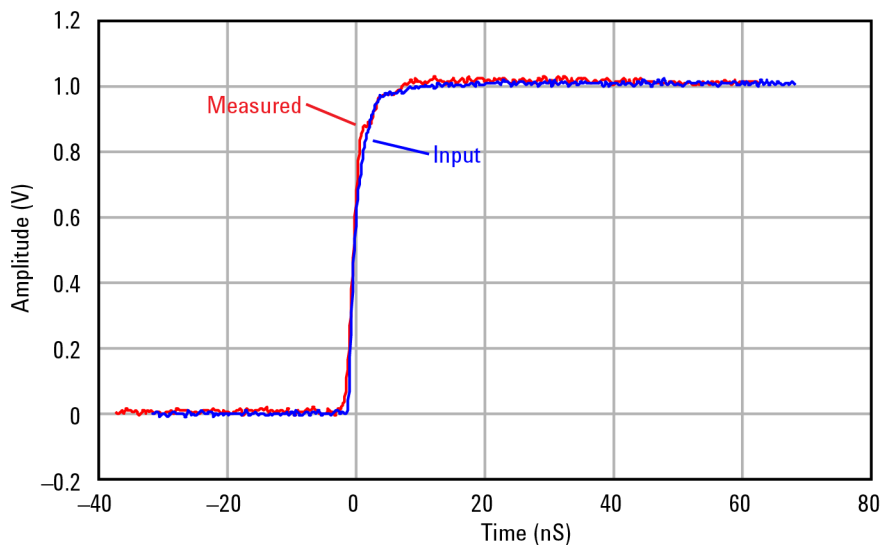

Input Step Signal

10 - 90% rise time:.....	3.5 ns
20 - 80% rise time:.....	2.2 ns

Measured Step Response

10 - 90% rise time:.....	3.5 ns
20 - 80% rise time:.....	2.2 ns

Figure 15 N2818A Normalized Differential Step Response (50Ω)

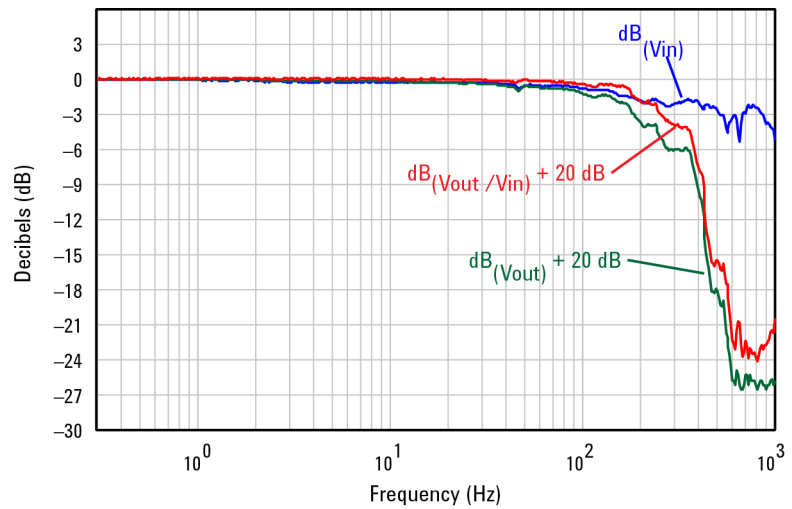

Figure 16 N2818A Frequency Response

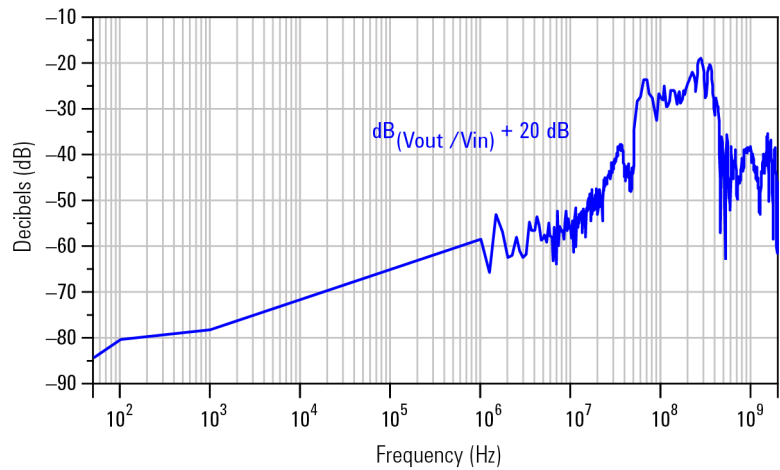

Figure 17 N2818A Frequency Response when Inputs Driven in Common Mode (CMRR)

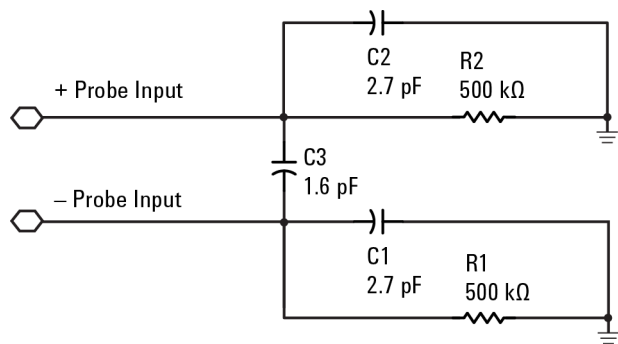

Figure 18 N2818A Input Impedance Equivalent Model Showing Measured Input Capacitance Values

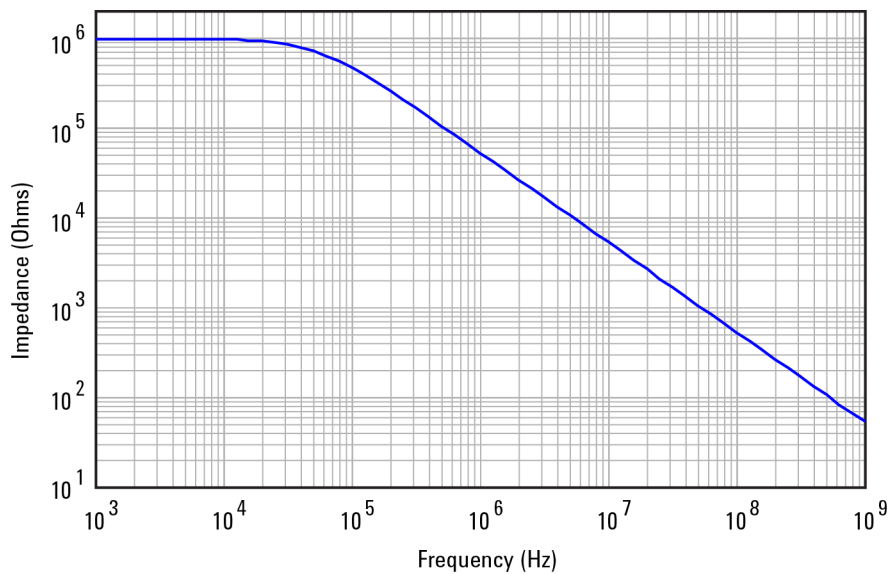

Figure 19 N2818A Typical Input Impedance Plot

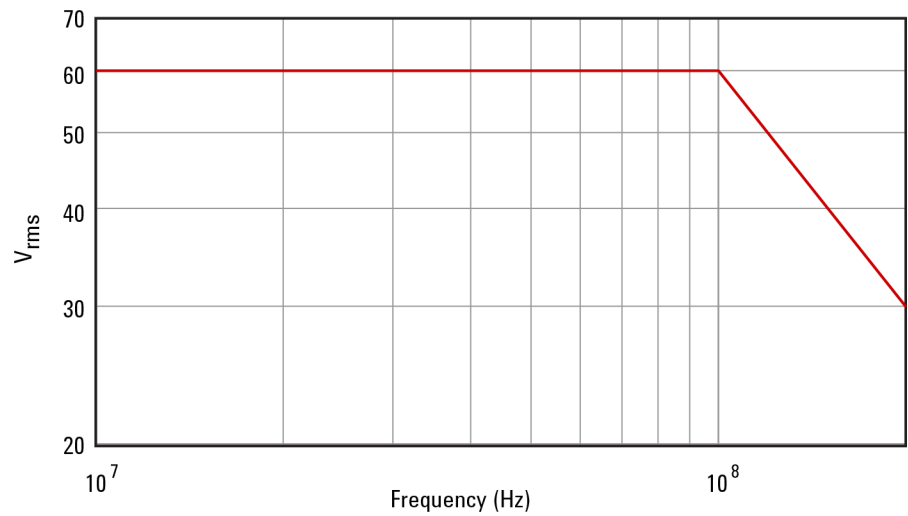
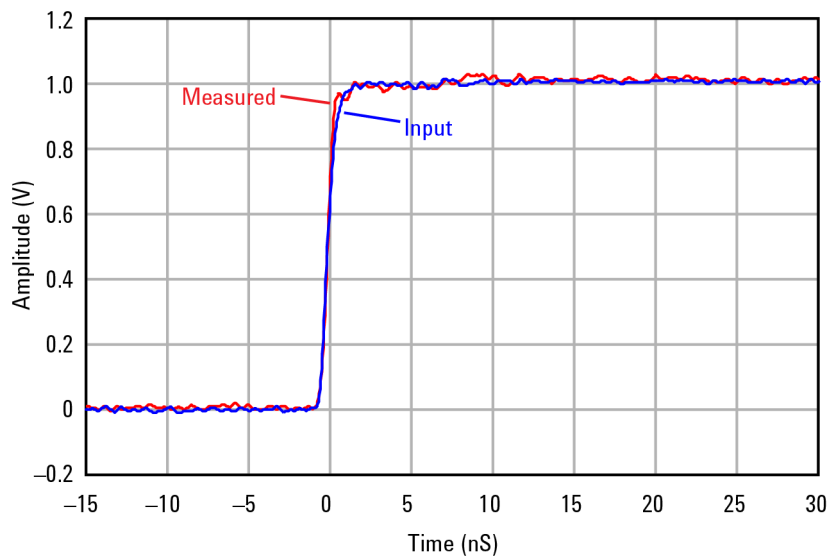

Figure 20 N2818A Typical Derating Curve of the Absolute Maximum Input Voltage (Either Input to Ground)

N2819A Performance Plots



Input	
10 - 90% rise time:.....	900 ps
20 - 80% rise time:.....	800 ps
Measured	
10 - 90% rise time:.....	900 ps
20 - 80% rise time:.....	800 ps

Figure 21 N2819A Normalized Differential Step Response (50Ω)

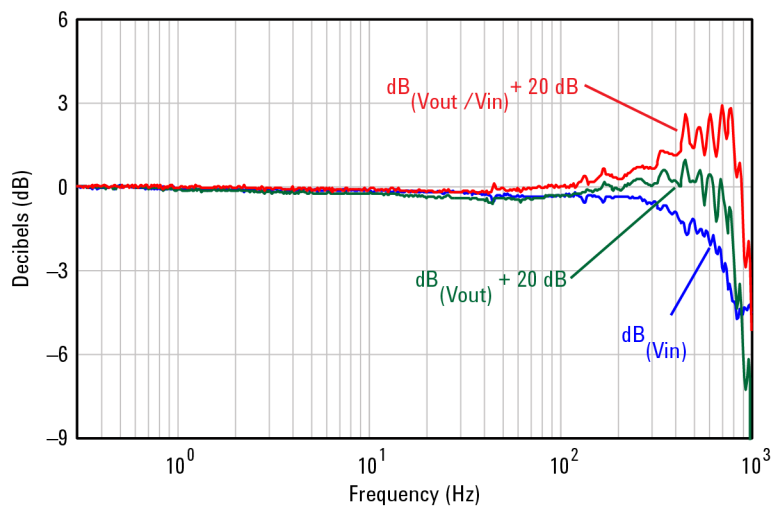

Figure 22 N2819A Frequency Response

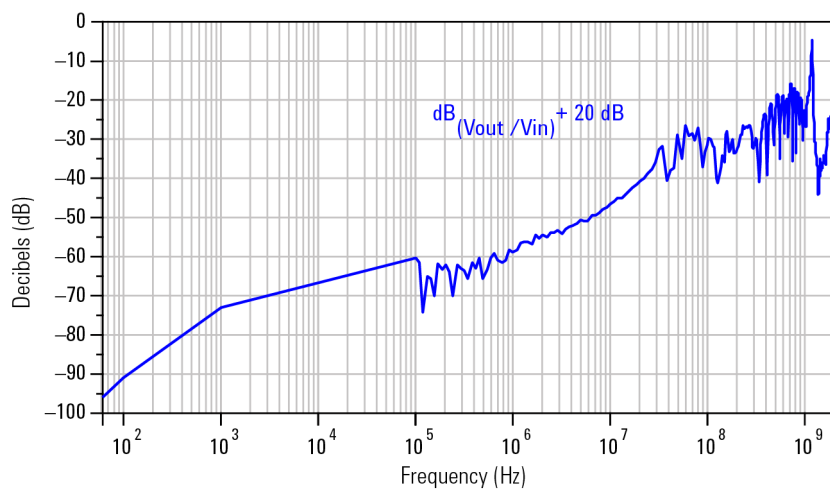

Figure 23 N2819A Frequency Response when Inputs Driven in Common Mode (CMRR)

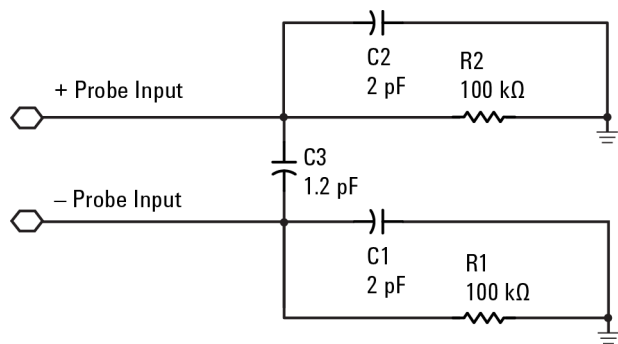

Figure 24 N2819A Input Impedance Equivalent Model Showing Measured Input Capacitance Values

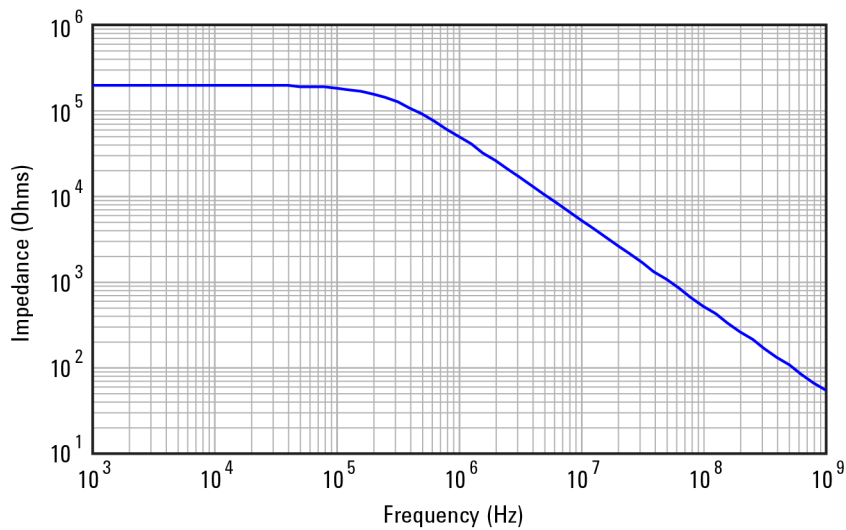

Figure 25 N2819A Typical Input Impedance Plot

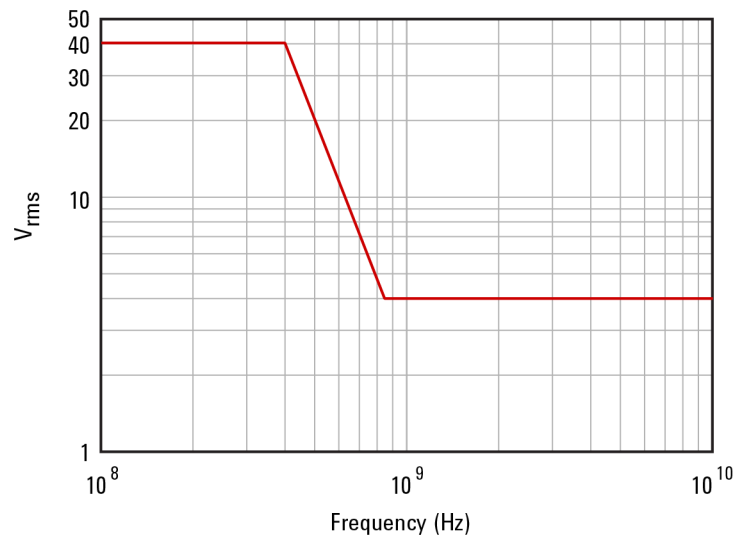

Figure 26 N2819A Typical Derating Curve of the Absolute Maximum Input Voltage (Either Input to Ground)

N2818A Performance Verification

The following procedure can be used to test the N2818A probe's DC differential gain accuracy and bandwidth, which are warranted specifications.

NOTE

The recommended test interval is 1 year.

Table 11 Required Test Equipment

Description	Critical Specifications	Recommended Model Part Number	Functions
Digitizing Oscilloscope	Bandwidth: >200 MHz 1 M Ω /50 Ω selectable input	Keysight MS09254A	Display probe output
Signal Generator Precision DC voltage source	Amplitude accuracy: less than or equal to 0.25% 1 M Ω / 50 Ω selectable load Sine wave greater than or equal to 200 MHz	Fluke 9500B High Performance Oscilloscope Calibrator or Keysight E8257D+1EU option	Signal source for DC gain and bandwidth
BNC Adapter	BNC (f) to Dual Banana (m) Adapter	Keysight 1251-2277	Interconnection between probe and generator
50 Ω BNC Feed Through Adapter	50 Ω precision feed through	Keysight 0960-0301	Termination between probe and calibrator for bandwidth verification

Scope Vertical Accuracy

- 1 Configure the oscilloscope to the following settings:
 Amplitude Scale (Channel 1):.....20 mV/div
 Amplitude Scale (Channel 2):.....500 mV/div
 Time Scale:.....200 ms/div
 Acquisition mode:.....32 averages
 Input impedance:.....50 Ω
 Trigger:.....Channel 2
- 2 On the 9500B calibrator, configure **CH2** to the following settings:
 Type:.....TRIGGER
 Load:.....50 Ω
- 3 On the 9500B, connect the **CH2** active head to channel 2 on the oscilloscope. Connect the **CH1** active head to channel 1 on the oscilloscope
- 4 On the N9500B, set **CH1** to the following settings and enable the output:
 Waveform:.....square wave
 Load:.....1 M Ω
 Amplitude:.....0.1V pk-pk
 Frequency:.....1 kHz
- 5 On the oscilloscope, select the amplitude measurement and record the DC amplitude (approximately 100 mV) of the square wave. This measurement is only the oscilloscope.

DC Differential Gain

- 1 Disable the 9500B's output and disconnect the active head from channel 1 of the oscilloscope.
- 2 Connect the N2818A probe output to channel 1 of the oscilloscope.
- 3 Attach the BNC adapter to the 9500B's **CH1** active head.
- 4 Attach the differential probe input leads by clipping the alligator clamp to the BNC adapter banana post.
- 5 On the N9500B, configure **CH1** to the following settings and enable the output:
 Waveform:.....square wave
 Load:.....1 M Ω
 Amplitude:.....1V
 Frequency:.....1 kHz
- 6 Enable the output of the calibrator.

- 7 Record the DC amplitude of the square wave and divide 10 into just the amplitude of the oscilloscope. Verify that the probe gain accuracy is $\pm 2\%$ + scope gain accuracy. Record the test results as DC Differential Gain Accuracy in [Table 12](#) on page 39.

Bandwidth

- 1 Disable the 9500B's output.
- 2 Connect the 50 Ω BNC feed through adapter to the N9500B's **CH1** active head.
- 3 Attach the BNC (f)-to-banana post adapter to the BNC feed through adapter.
- 4 Attach the differential probe input leads by clipping the alligator clamp to the BNC adapter banana post.
- 5 Enable the 9500B's output.
- 6 Configure the oscilloscope to the following settings:
Amplitude Scale (Channel 1):.....500 mV/div
Time Scale:.....2 ns/div
Acquisition mode:.....Peak Detect
- 7 Center the trace on the oscilloscope.
- 8 On the N9500B, configure **CH1** to the following settings:
Waveform:.....sine wave
Load:.....1 M Ω
Amplitude:.....3V pk-pk
Frequency:.....200 MHz
- 9 Measure the peak-to-peak amplitude on the oscilloscope. It should be greater than or equal to 2.12 V – scope vertical accuracy. Record the test results as Bandwidth in [Table 12](#) on page 39.
- 10 Disable the N9500B's output and disconnect the probe input.

Table 12 N2818A Performance Test Record

Certification Details			
Serial Number:		Tested By:	
Certification Date:		Recommended Date of Next Certification:	
Certification Temperature:			
Test	Probe Setting	Test Limits	Test Results
DC Differential Gain Accuracy	10:1	98 mV – scope vertical accuracy to 102 mV + scope vertical accuracy	
Bandwidth	10:1	\pm (2.12 V – scope vertical accuracy)	

N2819A Performance Verification

The following procedure can be used to test the N2819A probe's DC differential gain accuracy and bandwidth, which are warranted specifications.

NOTE

The recommended test interval is 1 year.

Table 13 Required Test Equipment

Description	Critical Specifications	Recommended Model Part Number	Functions
Digitizing Oscilloscope	Bandwidth: >1 GHz 1 M Ω /50 Ω selectable input	Keysight MS09254A	Display probe output
Signal Generator Precision DC voltage source	Amplitude accuracy: less than or equal to 0.25% 1 M Ω /50 Ω selectable load Sine wave greater than or equal to 800 MHz	Fluke 9500B or Keysight E8257D+1EU option	Signal source for DC gain and bandwidth
Performance Verification (PV) Fixture	50 Ω impedance controlled micro-strip trace	Keysight E2655C	Probing trace for bandwidth test
Terminator	50 Ω matched load		Termination for the PV fixture
BNC Adapter	BNC (f) to SMA (m)		Interconnection between calibrator and PV fixture
BNC Adapter	BNC (f) to Dual Banana (m) adapter	Keysight 1251-2277	Termination between probe and calibrator

Scope Vertical Accuracy

- 1 Configure the oscilloscope to the following settings:

Amplitude Scale (Channel 1):.....20 mV/div
 Amplitude Scale (Channel 2):.....500 mV/div
 Time Scale:.....200 ms/div
 Acquisition mode:.....32 averages
 Input impedance:.....50 Ω .
 Trigger:.....Channel 2

- 2 On the 9500B calibrator, configure **CH2** to the following settings:
 Type:.....TRIGGER
 Load:.....50 Ω
- 3 On the 9500B, connect the **CH2** active head to channel 2 on the oscilloscope. Connect the **CH1** active head to channel 1 on the oscilloscope
- 4 On the N9500B, set **CH1** to the following settings and enable the output:
 Waveform:.....square wave
 Load:.....1 M Ω
 Amplitude:.....0.1V pk-pk
 Frequency:.....1 kHz
- 5 On the oscilloscope, select the amplitude measurement and record the DC amplitude (approximately 100 mV) of the square wave. This measurement is only the oscilloscope.

DC Differential Gain

- 1 Disable the 9500B's output and disconnect the active head from channel 1 of the oscilloscope.
- 2 Connect the N2818A probe output to channel 1 of the oscilloscope.
- 3 Attach the BNC adapter to the 9500B's **CH1** active head.
- 4 Attach the differential probe input leads by clipping the alligator clamp to the BNC adapter banana post.
- 5 On the N9500B, configure **CH1** to the following settings and enable the output:
 Waveform:.....square wave
 Load:.....1 M Ω
 Amplitude:.....1V
 Frequency:.....1 kHz
- 6 Enable the output of the calibrator.
- 7 Record the DC amplitude of the square wave and divide 10 into just the amplitude of the oscilloscope. Verify that the probe gain accuracy is $\pm 2\%$ + scope gain accuracy. Record the test results as DC Differential Gain Accuracy in [Table 14](#) on page 43.

Bandwidth

- 1 Disable the 9500B's output.
- 2 Connect the PV fixture to the N9500B's **CH1** active head.

- 3 Configure the oscilloscope to the following settings:
Amplitude Scale (Channel 2):.....500 mV/div
- 4 On the 9500B calibrator, configure **CH2** to the following settings:
Type:.....TRIGGER
Load:.....50 Ω
- 5 On the 9500B, connect the **CH2** active head to channel 2 on the oscilloscope.
- 6 Terminate PV fixture's 50 Ω trace with the matched 50 Ω terminator.
- 7 Insert the probe's variable pitch signal pins into the probe tip.
- 8 Use a probe positioner to gently place the probe pin tips onto the PV fixture's center conductor and ground plane as identified in [Figure 27](#).

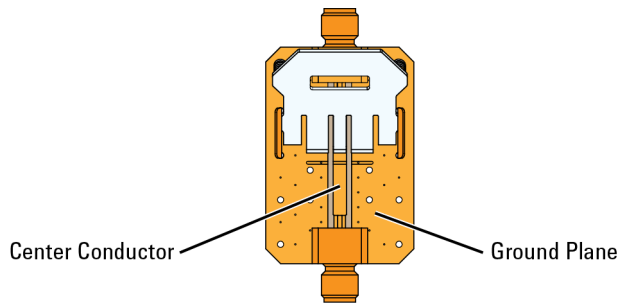

Figure 27 Probing Locations on PV Fixture

- 9 Enable the 9500B's output.
- 10 Configure the oscilloscope to the following settings:
Amplitude Scale (Channel 1):.....500 mV/div
Time Scale:.....2 ns/div
Acquisition mode:.....Peak Detect
- 11 Center the trace on the oscilloscope.
- 12 On the N9500B, configure **CH1** to the following settings:
Waveform:.....sine wave
Load:.....50 Ω
Amplitude:.....3V pk-pk
Frequency:.....800 MHz
- 13 Measure the peak-to-peak amplitude on the oscilloscope. It should be greater than or equal to 2.12 V – scope vertical accuracy. Record the test results as Bandwidth in [Table 14](#).
- 14 Disable the N9500B's output and disconnect the probe input.

Table 14 N2819A Performance Test Record

Certification Details			
Serial Number:		Tested By:	
Certification Date:		Recommended Date of Next Certification:	
Certification Temperature:			
Test	Probe Setting	Test Limits	Test Results
DC Differential Gain Accuracy	10:1	98 mV - scope vertical accuracy to 102 mV + scope vertical accuracy	
Bandwidth	10:1	\pm (2.12 V - scope vertical accuracy)	

Returning the Probe for Service

If the probe is found to be defective we recommend sending it to an authorized service center for all repair needs. Perform the following steps before shipping the probe back to Keysight Technologies for service.

- 1 Contact your nearest Keysight sales office for information on obtaining an RMA number and return address.
- 2 Write the following information on a tag and attach it to the malfunctioning equipment.
 - Name and address of owner
 - Product model number (for example, N2818A)
 - Product Serial Number (for example, MYXXXXXXXX)
 - Description of failure or service required.
- 3 Protect the probe by wrapping in plastic or heavy paper.
- 4 Pack the probe in the original carrying case or if not available use bubble wrap or packing peanuts.
- 5 Place securely in sealed shipping container and mark container as "FRAGILE".

NOTE

If any correspondence is required, refer to the product by serial number and model number.

Contacting Keysight Technologies

For technical assistance, contact your local Keysight Call Center.

- In the Americas, call 1 (800) 829-4444
- In other regions, visit <http://www.keysight.com/find/assist>
- Before returning an instrument for service, you must first call the Call Center at 1 (800) 829-4444.

Index

B

bandwidth, 25

C

capacitance, 25
care, probe, 6
channel identification rings, 7
characteristics, 25
cleaning, 7
compatible oscilloscopes, 6

D

DC blocking capacitor, 11, 18
characteristics, 27

E

Electrical Specifications and
Characteristics, 25
Environmental Specifications, 26
extension leads, 11, 18

G

grounding probe, 12, 16

I

Infiniium oscilloscope, 6
InfiniiVision oscilloscope, 6
input resistance, 25
inspecting, 7

K

Keysight Technologies, 44

M

Mechanical Characteristics, 26
micro IC clips, 11, 18

N

N2818A accessories, 8
N2818A Optional Accessories, 9
N2819A accessories, 10

O

offset adjustment tool, 11
oscilloscope
compatibility, 6
Infiniium, 6
InfiniiVision, 6

P

performance plots
N2818A, 28
N2819A, 32
performance verification
N2818A, 36
N2819A, 40
pincer clips, 11, 18
probe
cable care, 6
cleaning, 7
grounding, 12, 16
inspecting, 7
service, 44

R

repair, 44
replacement kit
for N2818A, 8

for N2819A, 10
returning for service, 44

S

safety, 21
Safety Considerations, 21
Safety Specifications, 26
safety warnings, 21
service, 44
single signal pin, 11

V

variable pitch pins, 17
variable pitch spacing adapter, 11

